



CADENCE

SMART TECH



SMART AMP SERIES // OWNERS MANUAL

Thank you for purchasing this Cadence ZRS Smart Amp Series amplifier. Over the years, the technology used to create audio amplifiers has grown by leaps and bounds. We have tens of thousands of satisfied customers still using our first generation Ultra Drive amplifiers which are more than 19 years old. Our competition is satisfied with just continuing to build the same units year after year without thought for improvement, but not Cadence. We consider it our mission to use our expertise in developing the latest technologies and to bring you the absolute best sounding, most powerful amplifiers on the market and of course at a reasonable price. We are very proud to introduce the ZRS Smart Series amplifiers featuring C-FORCE technology, “ARVA” and “ADR” circuitry. You will be amazed at the quality and power that these new amps offer. You will “Boom-Harder!” with ZRS Smart Series amplifiers.

We have spared no expense in designing these amplifiers, creating the most rugged, reliable, powerful and best performing amplifiers. In fact we are so sure of the quality we backup every ZRS Smart Series amplifier with our exclusive two-year warranty which exemplifies our commitment to excellence in car audio musical reproduction. (See enclosed warranty card for details.)

Please read this installation guide carefully for proper use of your Cadence power amplifier. Should you need technical assistance during or after your installation please call our technical-line M - Th between 9:30 am and 5:00 PM EST at (732) 370-5400. Read this entire guide fully before attempting your installation.

WARNING: BE AWARE! Use of this amplifier at extreme high volumes for extended periods of time may cause hearing loss and or hearing damage. During periods of prolonged high volume levels it is recommended that you use ear safety devices. Playing Cadence amplifiers at high volume levels while driving will impair your ability to hear necessary traffic sounds. While driving always keep your sound volume at reasonable levels. We at Cadence want you listening for many years to come.

When installing the amplifier, secure it tightly. An unmounted amplifier in your car can cause serious injury to passengers and damage to your vehicle if it is set in motion by an abrupt driving maneuver or short stop.

FEATURES

GOLD PLATED TERMINALS:

All the terminals on the amplifier are solid brass and gold plated for high conductivity and minimum impedance loss. The power and ground terminals are extra large and capable of accepting 4-8 gauge wire. The speaker terminals can accept 14-16 gauge wire. When wiring the amplifier, be sure to strip just enough wire that fits into the terminal so that bare wires do not touch each other, or the amplifier chassis and cause a short circuit. We recommend using Cadence brand lug and spade connectors for optimum signal transfer.

MUTE CIRCUIT:

The ZRS Smart Series amplifiers feature an anti-thump, mute and delay circuit. This eliminates irritating speaker damaging turn-on and turn-off transients normally experienced with less expensive amplifiers.

BASS DRIVE EQUALIZATION CIRCUITRY:

A narrow "Q" shelving equalization circuit is included in the amplifiers. The equalization system is preset at 45Hz. The boost control allows you to add up to 18dB of Bass Drive effect. Utilize the Bass Drive to tailor your bass response to your systems needs. Please keep in mind that by adding Bass Drive you are adding stress on your speakers. Make sure your speakers can handle the extra power output! It would be foolish to add 18dB of gain to low excursion 8" and 10" Sub woofers or mid ranges and tweeters. It's a sure way to blow your speakers. The Bass Drive was designed for High Power sub woofers.

"ADR": ACTIVE DYNAMIC REGULATION

Cadence ZRS Smart Series amplifiers feature our proprietary ADR, Active Dynamic Regulated power supplies. 100% HexFET devices are utilized in the power supply for high speed (100KHz) switching frequencies. The power supplies are capable of supplying the main amplifier with a considerable amount of reserve voltage for peak "high demand" situations. The ADR circuit provides full bandwidth power for authoritative bass response, high current output into low impedance loads and increased headroom. The ADR is supplied with power via a high speed, high temperature capacitance bank and 100% pure copper rails on the PCB enabling fast transient response to musical demands.

"ARVA": AUTOMATIC RAIL VOLTAGE ADJUSTMENT CIRCUITRY

Cadence ZRS Smart Series amplifiers feature "ARVA" circuitry in their power supply. This

circuit constantly monitors the output stage and under high current demands will adjust the power supply rail voltages so that enough power is available for peak situations. The "ARVA" also improves the damping factor of the amplifier when playing low impedance mono loads. Cadence United Series amplifiers have tighter sounding bass reproduction thanks to this unique circuitry.

SUPER CLASS AB AUDIO STAGE PERFORMANCE:

The audio output section of the ZRS Smart Series amplifiers feature Japanese studio grade, high current Bi-Polar audio transistors. Unlike other manufacturers who use a host of different type of transistors, not originally designed for audio output, i.e.: power supply transistors, motor control transistors to produce the audio signal, (You can only imagine what they sound like.) Cadence uses only true audio transistors in the audio section of these amplifiers. These transistors were designed and engineered to produce music. That's why Cadence amplifiers clearly sound better. They are cleaner with lower distortion, higher current capable and more reliable. We challenge you to test listen a Cadence amplifier and hear the difference yourself.

SUPER CLASS D FULL RANGE:

The D250.2 and D350.2 utilize our cutting edge full range class D technology. These amps feature sound that is crystal clear and ultra smooth without the distortion or harshness typical of full range class D designs.

CLIP LIMITER (MONOBLOCK AMPS ONLY):

When activated this feature stops your amp from going into clipping mode thus limiting the amount distortion. This is achieved by compressing the signal coming into the amp. For SPL applications turn limiter off. For SQL applications leave the limiter on.

BASS FOCUS:

The ZRS Smart series amplifiers feature our exclusive BASS FOCUS circuitry which works as a variable Q control. By supplying up to 7dB of boost, you can compensate for drivers in to small an enclosure so a 10" woofer can sound like a 12" woofer and a 12" can sound like a 15" woofer. Small dash and door speakers will also benefit increasing their power handling capabilities.

SMART TECH MONITORING CIRCUITRY:

ZRS Smart Series amplifiers feature our exclusive Smart Tech monitoring circuit. The system computer monitors amplifier temperature, input voltage, channel distortion with clipping, input overload, and speaker short circuit. This information is displayed on the top mounted easy to read LCD screen notifying the user of the amplifiers status at all times.

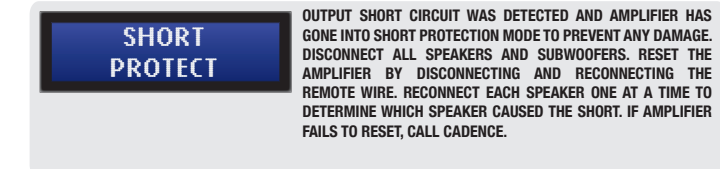
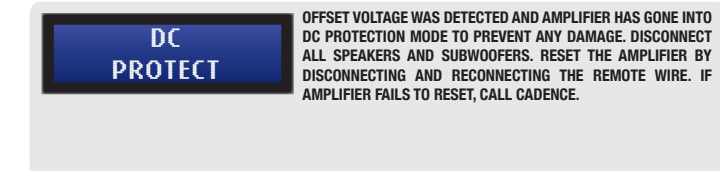
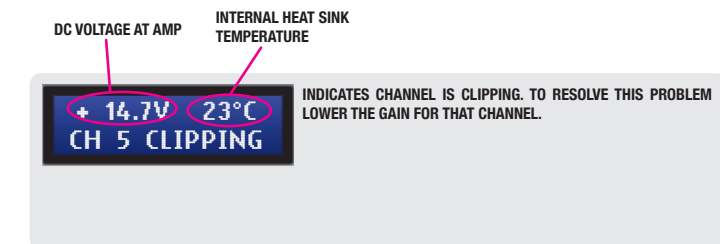
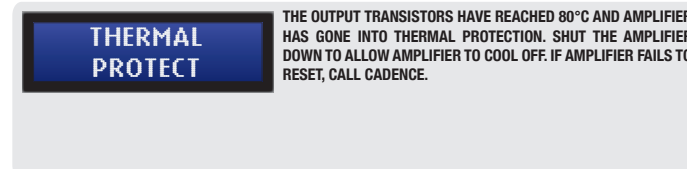
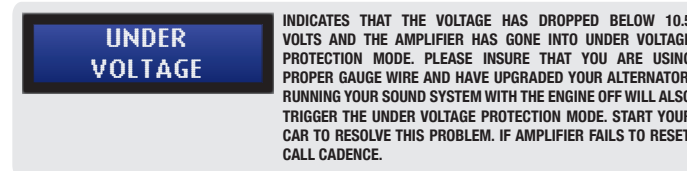

INSTALLATION

BATTERY VOLTAGE:

Cadence ZRS Smart Series amplifiers are rated and regulated to 13.8 volts and below. Increasing voltage to 14.4 volts will increase the power output of the amplifier in the same proportion. Maximum input voltage is 16 volts while the minimum voltage is 12 volts.

***** DO NOT EXCEED 16 INPUT VOLTAGE. *****

PROTECTION CIRCUITRY:

Cadence amplifiers incorporate many outstanding protection circuits to help protect the amplifier from being damaged during operating conditions.

Thermal Protection: When the amplifier reaches an unsafe operating temperature of 80 degrees Celsius the amplifier will turn off. Once the amplifier cools down, simply reset the amplifier by its Remote connection, (turn the amplifier off and then on again once you have given the amplifier a chance to cool down) and the amp will once again begin to play.

If you live in a hot climate we suggest installing additional cooling fans in your trunk to exhaust the hot air which can build up in the trunk this will help keep the ambient temperature in the trunk as low as possible so that your amps work flawlessly and without any musical interruption.

Speaker Short Circuit Protection: Should your speakers short circuit due to voice coil burn out, or should the amplifier sense an impedance too low to handle the LCD display will indicate a diagnostic condition. Turn off your system, disconnect one speaker at a time and try to determine which speaker might be faulty. Correct the condition and restart the amplifier. You must reset the amplifier by turning it OFF and then ON again by the Remote power connection after correcting a diagnostic condition. (Turn your radio off and then on again.)

Clipping or total shutdown may also be a result of a bad ground connection or loose ground. If you find that your speakers and speaker wires are not shorted, please check your ground connection.

Input Overload Protection: This circuit will either shutdown the amplifier completely or make the amplifier spurt on and off indicating that it is in a diagnostic condition. Turn the system off and reduce the gain on the amplifier or volume from your head unit, this should result in a corrected condition.

DC Offset Protection: Should any DC voltage try to enter the amplifier via the speaker terminals it will cause the amplifier to shut down and not operate until this condition is remedied. This circuit will also protect damaging high DC voltages from reaching your speakers should your amplifier ever malfunction.

INSTALLATION BASICS:

Before you begin with your installation, disconnect the NEGATIVE (-) terminal from your car's battery. This safety precaution will avoid possible short circuits while wiring your amplifier. Cadence amplifiers operate on 12-volt negative ground systems only.

It is recommend that you layout your sound system design on paper first. This will help you during the installation so that you will have a wiring flow chart and not miss-wire any of your components.

Mount the amplifier in the trunk or hatch area of your vehicle. Never install an amplifier in the engine compartment or on the firewall. Please be sure to leave breathing room around the amplifier heat sink so that it can dissipate the heat it produces efficiently. The amplifier can be installed either horizontally or vertically.

When mounting the amplifier on the trunk floor, be sure to watch for your gas tank, gas lines and electrical lines. Do not drill or mount any screws where they might penetrate the gas tank of your car.

REMOTE TURN ON CONNECTION:

The remote turn on connection is located on the barrier strip next to the power and ground connections. This connection is responsible for turning the amplifier on and off with the rest of the system. A smaller gauge wire can be used to make this connection to your radio's power antenna lead. Should your system not have any turn on leads, you can wire the remote terminal to an accessory lead, which turns on, with your cars ignition.

POWER/GROUND WIRING:

The ZRS Smart Series amplifiers are supplied with built-in fuses, never replace the fuse that the amp came with, with one of a larger value.

We suggest you construct a Red wiring harness with 2 additional fuses. One fuse should be located near the car battery. This fuse near the battery offers protection against damage from short circuits to the car chassis between the battery and the amplifier. A second fuse closer to the amplifier offers additional safety to the amplifier itself. This fused red power wire should be attached to the amplifier power terminal marked **12V+**.

The wire harness should be made of red primary cable of at least 8 gauge for the D250.2 and at least 4 gauge for all other larger models. The harness should terminate in a large ring terminal for connection directly to the positive terminal of the car battery. Use a spade plug to attach the wire, which connects to the amplifier location marked **12V+**.

A second black color wire of equal gauge should be used as a ground connection to a welded chassis member. When connecting the ground wire make sure that there is no paint or other insulator blocking a good ground connection. When installing multiple amplifiers, mount them in close proximity so that they can all share the same ground point. Attach the black ground wire to the amplifier screw terminal marked **Ground**.

We recommend that you use the Cadence AMPKIT4 or AMPKIT8 amplifier installation kits, which contains all the cabling and accessories necessary for a good, reliable installation.

Over the years we have received amplifiers back to our service department with melted power/ground terminals. The cause of this is a bad ground connection. When there is a lack of good ground, heat builds up at the weakest point which happens to be the contact screw of the amplifier terminal. Over time the heat generated will begin to melt the terminal. It is a good practice to feel the power and ground wires with your hands, near their amplifier connection after having played the amp for a while. If the wires feel hot to the touch you probably have a bad or loose connection. If you are sure of your connections and the wires still feel hot to the touch, you should upgrade the gauge of wire to next heaviest gauge.

SETTING THE CONTROLS:

AUDIO PREAMP INPUT

The ZRS Smart Series amplifiers feature RCA pre amp inputs. Run RCA cables from

your sound source to the inputs of the amplifier. We suggest the use of high quality shielded RCA patch cords to help reduce and eliminate unwanted electrical noise to your system.

Be sure to run the RCA cables on the opposite side of the vehicle that you used to carry the power and ground leads of the amplifier.

USING THE BUILT-IN LOW PASS ELECTRONIC CROSSOVER

All the ZRS Smart Series amplifiers feature 12dB per octave fully adjustable low-pass and high pass electronic crossovers.

For Low Pass sub woofer systems, set the CROSSOVER MODE switch to LOW PASS. For 2 channel amps the knob marked LPF will control the low pass frequencies depending on the model anywhere from 45Hz to 250Hz. The D250.2, D350.2, and D100.4 feature a frequency multiplier button (10X) allowing you to reach frequencies ranging from 150Hz to 4.5KHz. A frequent error made is setting the low pass frequency too low, especially when using vented sub woofer enclosures. We recommend that for most installations you do not set the frequency knob lower than 80 - 100Hz (the 12 o'clock position).

When using D250.2, D350.2, and D100.4 amplifiers for component speakers or co-axials, you will want to set the CROSSOVER MODE switch to HIGH PASS. The HPF control knob adjusts the high pass frequencies between 10Hz and 300Hz. These amplifiers also feature a frequency multiplier feature (15x) allowing you to reach frequencies ranging from 150Hz to 4.5Khz. Do not attach tweeters directly to the amplifier, (even in the high pass mode) without a secondary passive crossover to protect them. 300Hz high pass is not a frequency high enough for tweeters.

SUBSONIC FILTERING

For sub woofer installations with a passive LP crossover, you can set the amplifier's CROSSOVER MODE selector to HIGH PASS while setting the HPF knob to 30Hz, this will act as SUBSONIC FILTER for all signals below 30Hz. This is especially useful for vented enclosures where the port tuning frequency falls below the sub woofer tuning frequency to protect against sub woofer unloading.

ADJUSTING THE SYSTEM

Once the system is operational, the first thing to do, is set all crossover points to approximate settings. In the case of the basic sub woofer system Low Pass filter crossover at 100 Hz or so. Set the Bass Boost equalizer controls to 0 dB (Flat Switch Position.)

Now you should set the amplifiers Input Sensitivity adjustment. The knob accessible on the side of the amplifier marked INPUT GAIN adjusts the input sensitivity from 150mV to 8 Volts.

To adjust the input sensitivity, turn the control using a small flat head screwdriver fully counter clock wise to the minimum position. Do not apply any pressure while turning as this might break the control unit. Adjust your radio volume level to maximum volume. Now turn the level control on the amplifier clockwise towards the Maximum marking until audible distortion occurs. When you begin to hear any distortion in the sound, back down one notch and your amp is set. It is helpful to have a second person to help you set the gain.

When setting up a multi-amp system, set each amplifier's gain separately. Start off with the bass amplifier, then adjust the highs amplifier's level control to match.

Once you are satisfied with the level control settings, use any equalizer controls to adjust the system tonal level for personal preference. Keep in mind that after equalizing, you may have to go back and reset the amplifiers level controls.

*** The level control of any car amplifier should not be mistaken for a volume control. It is a sophisticated device designed to match the output level of your source unit to the input level of the amplifier. Do not adjust the amplifier gain to maximum unless your input level requires it.

If your unit has been professionally installed please do not change the gain settings set by the installer, he is the professional!

Your system can also be extremely sensitive to noise when the LEVEL is set to maximum and does not match your input signal. The gain adjustments need to be made only once when first setting up the system.

USING THE ELECTRONIC CROSSOVER - 4 CHANNEL MODEL (D100.4)

The four channel model features separate crossovers for channels 1-2 and 3-4. All the ZRS Smart Series amplifiers feature 12dB per octave fully adjustable low-pass and high pass electronic crossovers.

FOUR CHANNEL AMPLIFIER CONFIGURATIONS:

1. All four channels High Pass for internal component speakers in doors and rear decks.
2. Channels 1 and 2 High Pass for front component speakers, while channels 3 and 4 are wired to sub woofers.
3. Bridge channels 1 and 2 for single high power subwoofer channel. Bridge channels 3 and 4 for second high power subwoofer channel.

For Low Pass systems, set the CROSSOVER MODE switch to LOW PASS. Now the knob marked FREQUENCY will control the low pass frequencies from 40Hz to 150Hz. A frequent mistake made is setting the low pass frequency too low, especially when using vented sub woofer enclosures. We recommend that for most installations you do not set the frequency knob lower than 100Hz (the 12 o'clock position).

When using the amplifiers for component speakers or coaxial, you will want to set the CROSSOVER MODE switch to HIGH PASS. The FREQUENCY control knob adjusts the high pass frequencies between 50Hz and 500Hz. Do not attach tweeters directly to the amplifier even in the high pass mode without a secondary passive crossover to protect them. 500Hz high pass is not a frequency high enough for tweeters.

PASSIVE SUBSONIC FILTERING

For sub woofer installations with a passive LP crossover, you can set the amplifier's CROSSOVER MODE selector to HIGH PASS while setting the FREQUENCY KNOB to 40Hz, this will act as SUBSONIC FILTER for all signals below 40Hz. This is especially useful for vented enclosures where the port tuning frequency falls below the sub woofer tuning frequency to protect against sub woofer unloading.

MOUNTING THE AMPLIFIERS:

Choose a convenient mounting location with unobstructed airflow.

The ZRS Smart amplifiers feature four mounting tabs located near the amplifiers four corners. Using the supplied screws and grommets, gently mount the amplifier into position.

*** Do not over tighten the screws.***

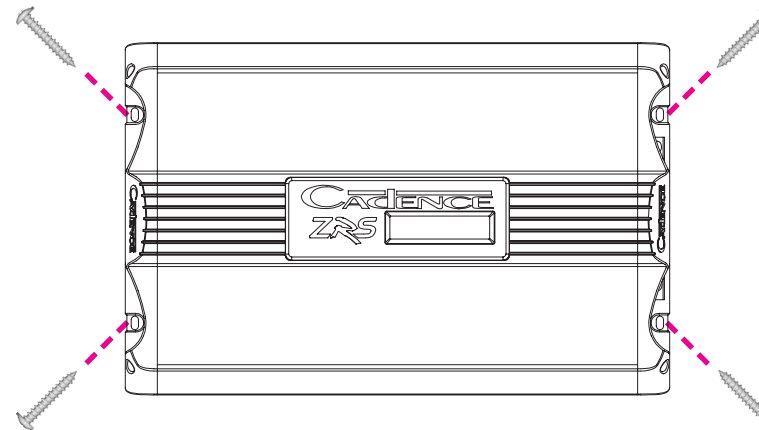

The ZRS Smart Series amplifiers are supplied with built-in fuses, never replace the fuse that the amp came with, with one of a larger value.

We suggest you construct a Red wiring harness with 2 additional fuses. One fuse should be located near the car battery. This fuse near the battery offers protection against damage from short circuits to the car chassis between the battery and the amplifier. A second fuse closer to the amplifier offers additional safety to the amplifier itself. This fused red power wire should be attached to the amplifier power terminal marked 12V+.

The wire harness should be made of red primary cable of at least 4 gauge for all ZRS Smart Series amplifiers. The harness should terminate in a large ring terminal for connection directly to the positive terminal of the car battery. Use a spade plug to attach the wire, which connects to the amplifier location marked 12V+.

A second black color wire of equal gauge should be used as a ground connection to a welded chassis member. When connecting the ground wire make sure that there is no paint or other insulator blocking a good ground connection. When installing multiple amplifiers, mount them in close proximity so that they can all share the same ground point. Attach the black ground wire to the amplifier screw terminal marked Ground.

We recommend that you use the Cadence AMPKIT4 or AMPKIT8 amplifier installation kits, which contains all the cabling and accessories necessary for a good, reliable installation.

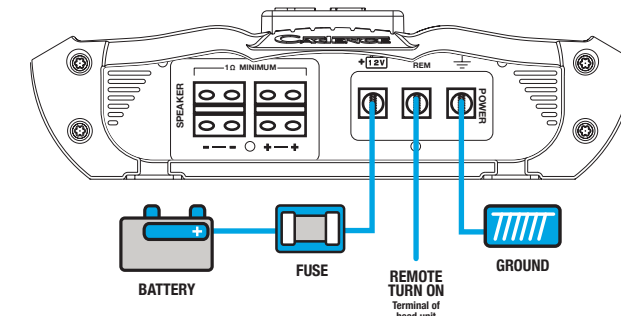

4 CHANNEL AMP CLONE FEATURE

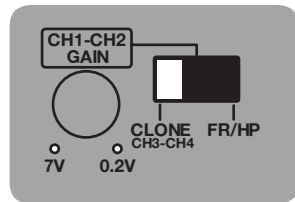

The D100.4 features a unique CLONE FUNCTION to assist in setting up a 2-channel bridged system with perfect gain and crossover tracking between the speakers. Typically when setting up a system you would need to set up channels 1 - 2 and then channels 3 - 4 crossovers and gains separately not guaranteeing perfect balance or frequency cutoffs. By using the CLONE FUNCTION you can control channels 1 - 2 from the processed signals of channels 3 - 4 thereby guaranteeing that all 4 channels are getting identical voltages and have their crossover settings identical at identical frequencies. Here is how you do it:

1. PLUG STEREO RCA INTO CHANNELS 3 - 4 AND SET THE MODE SWITCH TO 4CH ("UP" POSITION).

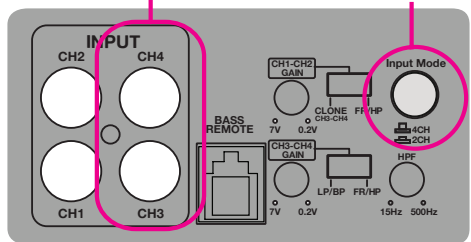

2. SET THE CROSSOVER MODE SWITCH TO CLONE CH3 - CH4. THIS WILL SEND THE PROCESSED SIGNAL OF CHANNELS 3 AND 4 TO

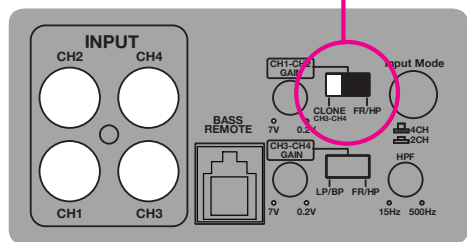

3. NOW ALL CONTROLS FOR CHANNELS 1 - 2 WILL BE NON FUNCTIONAL. ALL CROSSOVER SETTINGS WILL BE CONTROLLED FROM CHANNELS 3 - 4

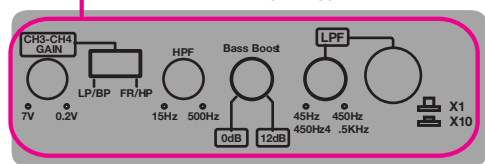

4 CHANNEL AMP WITH 2 CHANNEL INPUT

If your head unit has only one pair of Left and Right RCA output jacks, plug them into RCA input jacks 1 and 2 of the amplifier and set the Input mode switch to the 2CH position.

The amplifier preamp circuit will automatically route the signals to channels 3 and 4 thereby preserving your Left and Right Balance control but with no Fade control Front to Rear.

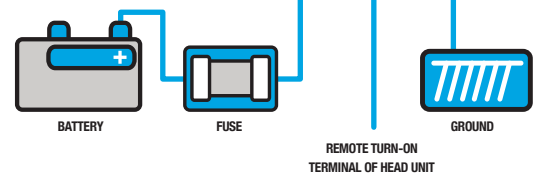
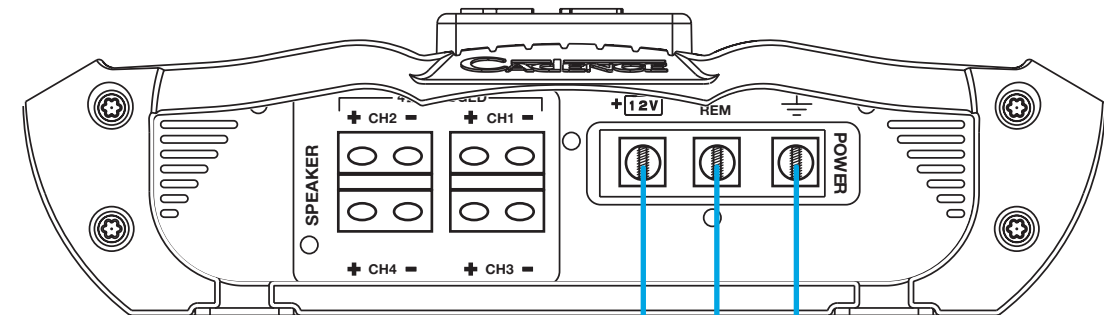
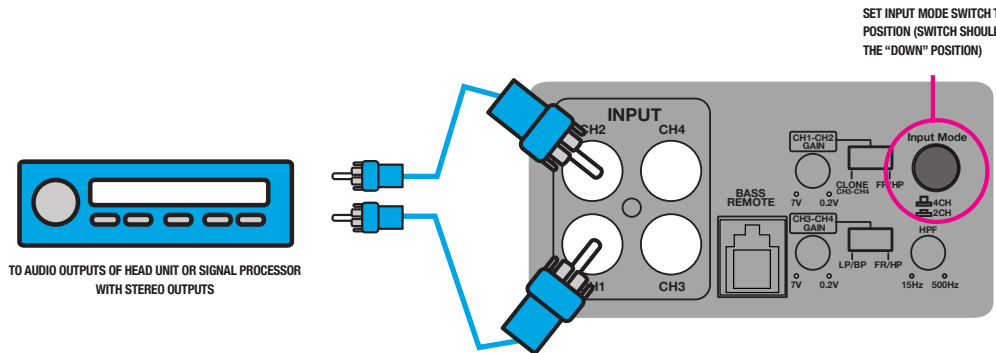

SET INPUT MODE SWITCH TO 2CH POSITION (SWITCH SHOULD BE IN THE "DOWN" POSITION)

4 CHANNEL AMP WITH 4 CHANNEL INPUT

If your head unit has 2 pairs of RCA output jacks, input Front Left and Front Right in to Channels 1 and 2. Then attach radio output Rear Left and Rear Right to Channels 3 and 4. Set the Input Mode Switch to 4Ch position. The pre amp circuitry will not mix any signals thereby preserving full Left to Right Balance and Front to Rear fader control.

Should your head unit have an additional subwoofer RCA output, that typically needs to be attached to a separate subwoofer amplifier.

When configuring a 4 channel amplifier to a 3 channel system, you can use an RCA Y adaptor to send the subwoofer preamp signal to channels 3 and 4 and bridge those channels to the subwoofer. Use Y adaptors to mix channels 1 and 3 and input them into RCA Channel 1, then mix channels 2 and 4 and input them into RCA channel 2. The result will be preserved Left and Right balance with constant subwoofer output.

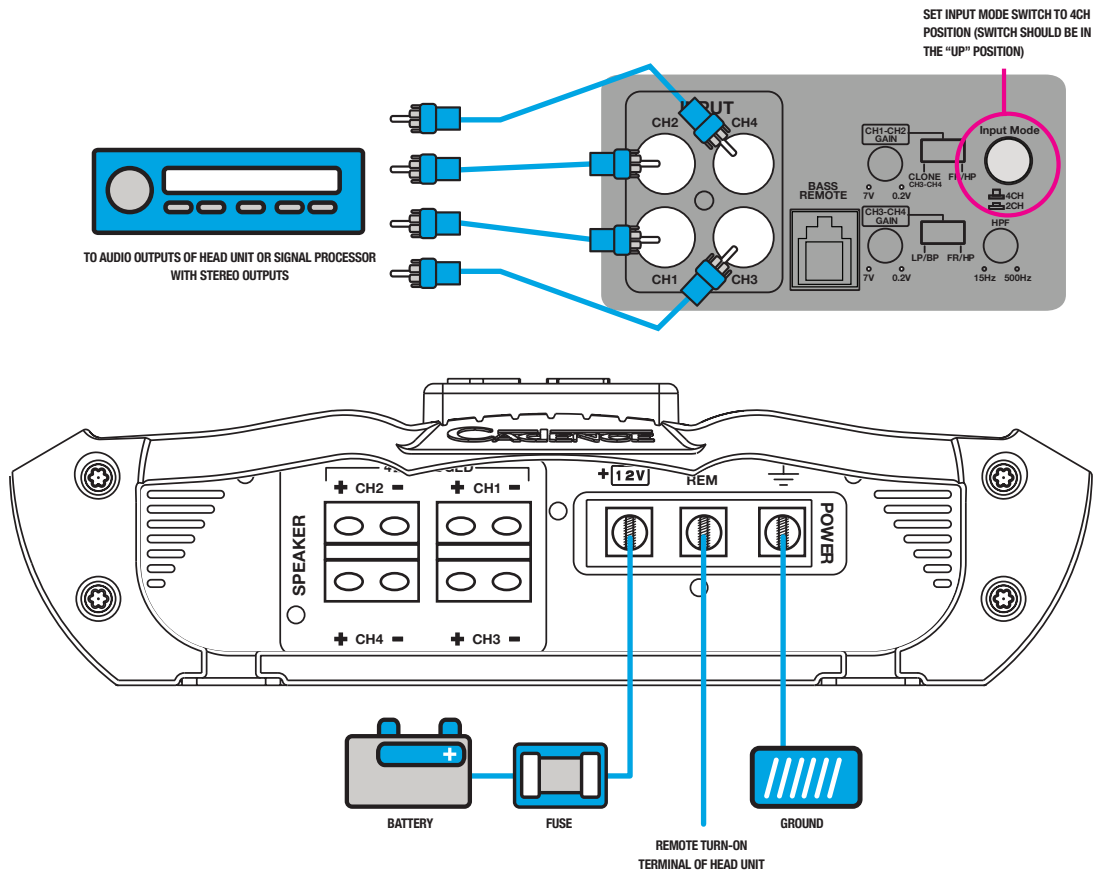

Install any combination of speakers independently on all 4 channels being careful not to load any single channel below 2 ohm stereo. For typical 6" x 9" or 6.5" or component speaker installs, set the Crossover Mode Switch to Full Range.

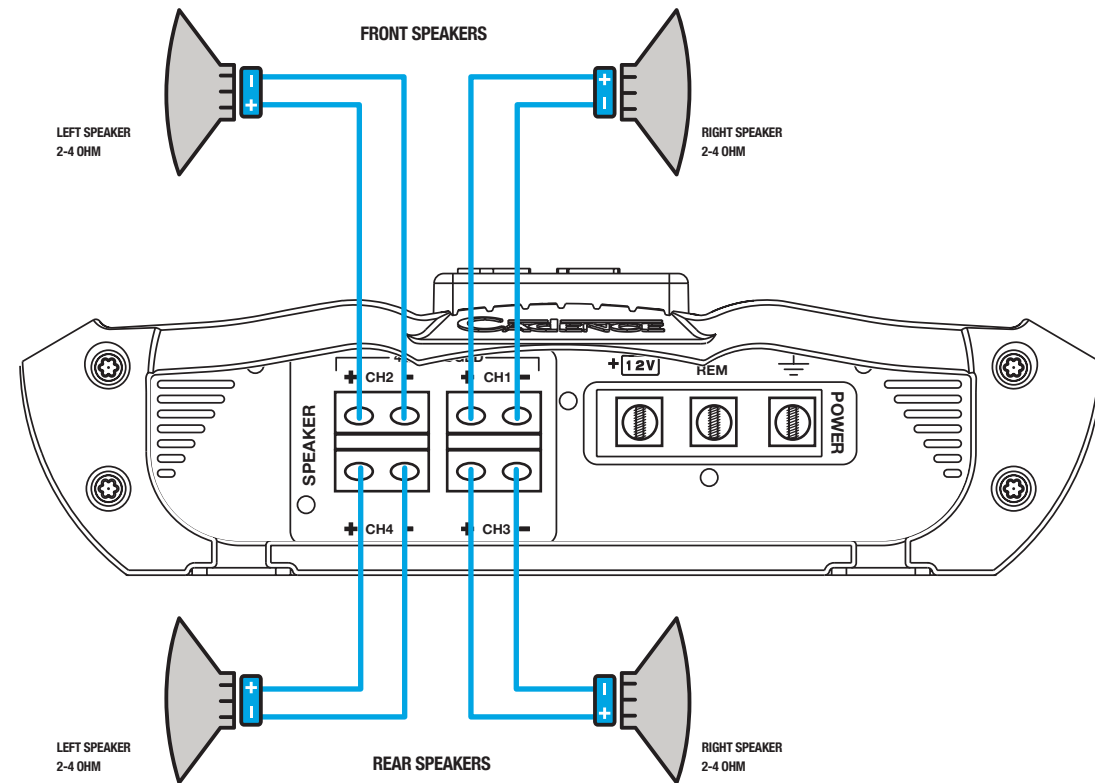
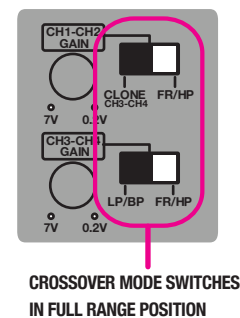

4 CHANNEL AMPLIFIER BRIDGED TO 2 CHANNELS

When bridging the four channel amplifier, make sure that your final woofer impedance on each bridged channel is no lower than 4 ohms. Set the Crossover Mode Switch to Low Pass and begin by setting the crossover frequency control to 100Hz and tuning from there. The dashboard bass remote control works only on channels set to Low Pass.

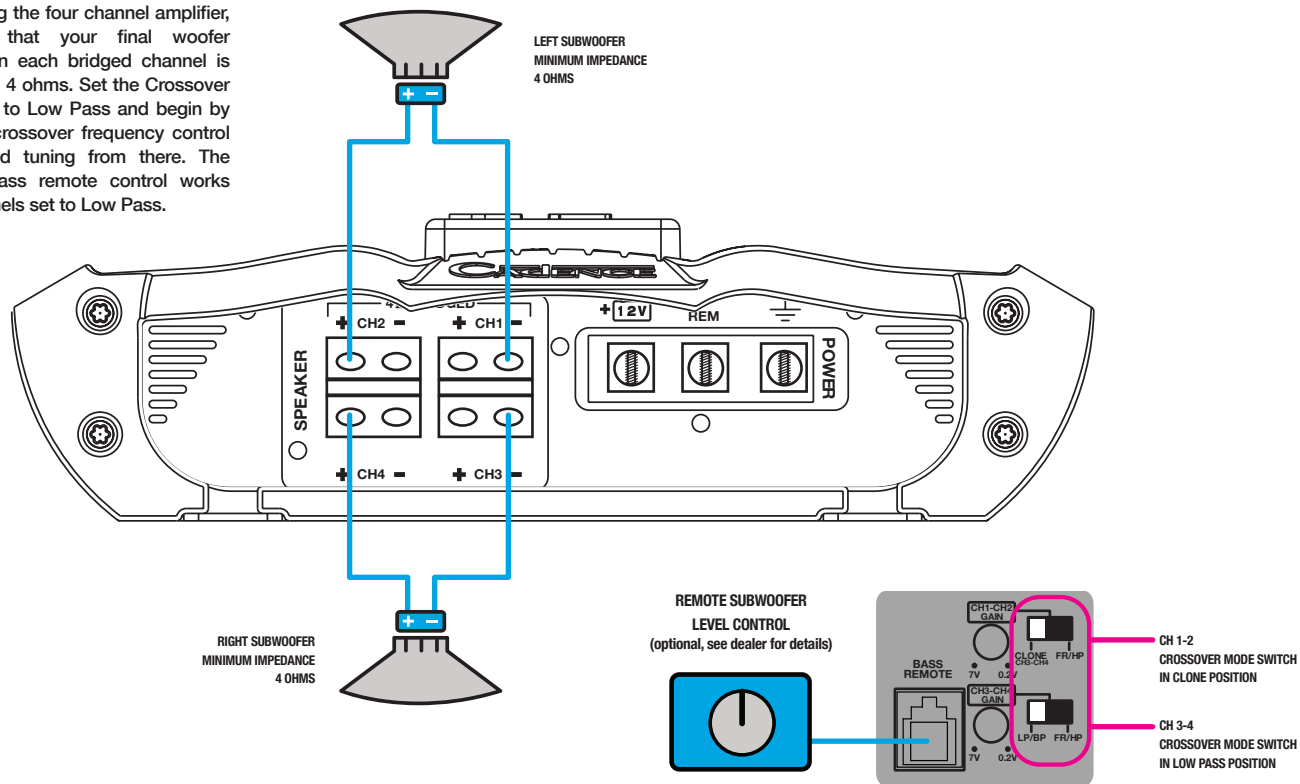

4 CHANNEL AMPLIFIER IN 3 CHANNEL MODE

Channels 1 and 2 should be wired to speakers no lower than 2 ohm loads per channel in stereo. Channel 3 and 4 should be bridged as per the diagram wiring the woofer to Channel 3 positive side (+) and Channel 4 negative side (-) terminals.

Set the crossover mode switch of Channels 1 and 2 to either Full Range or High Pass, while Channels 3 and 4 should be set to Low Pass. Remember that the Dashboard Bass Remote Control works only on Low Pass Channels.

Please see page 11 for RCA input configuration details and instructions when wiring a 3 channel system.

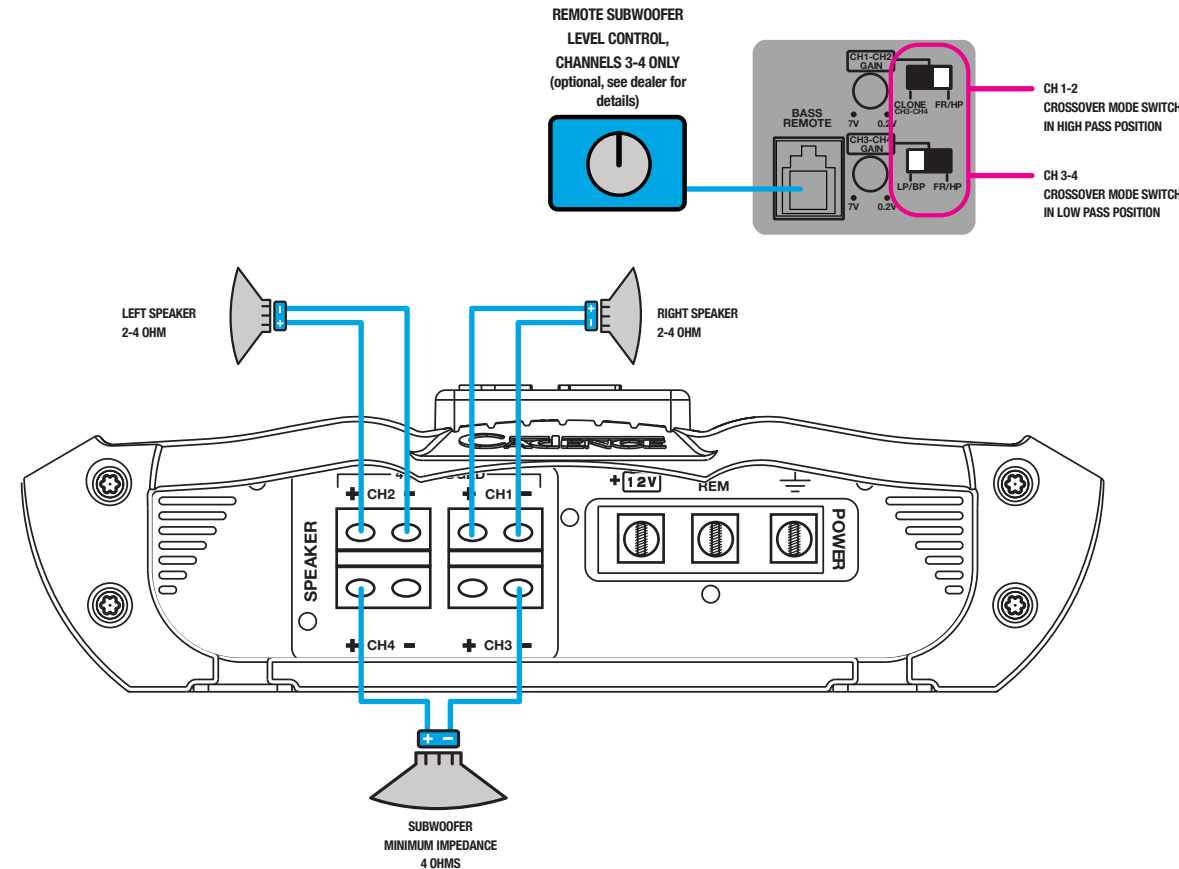

4 CHANNEL AMPLIFIER IN 3 CHANNEL MODE

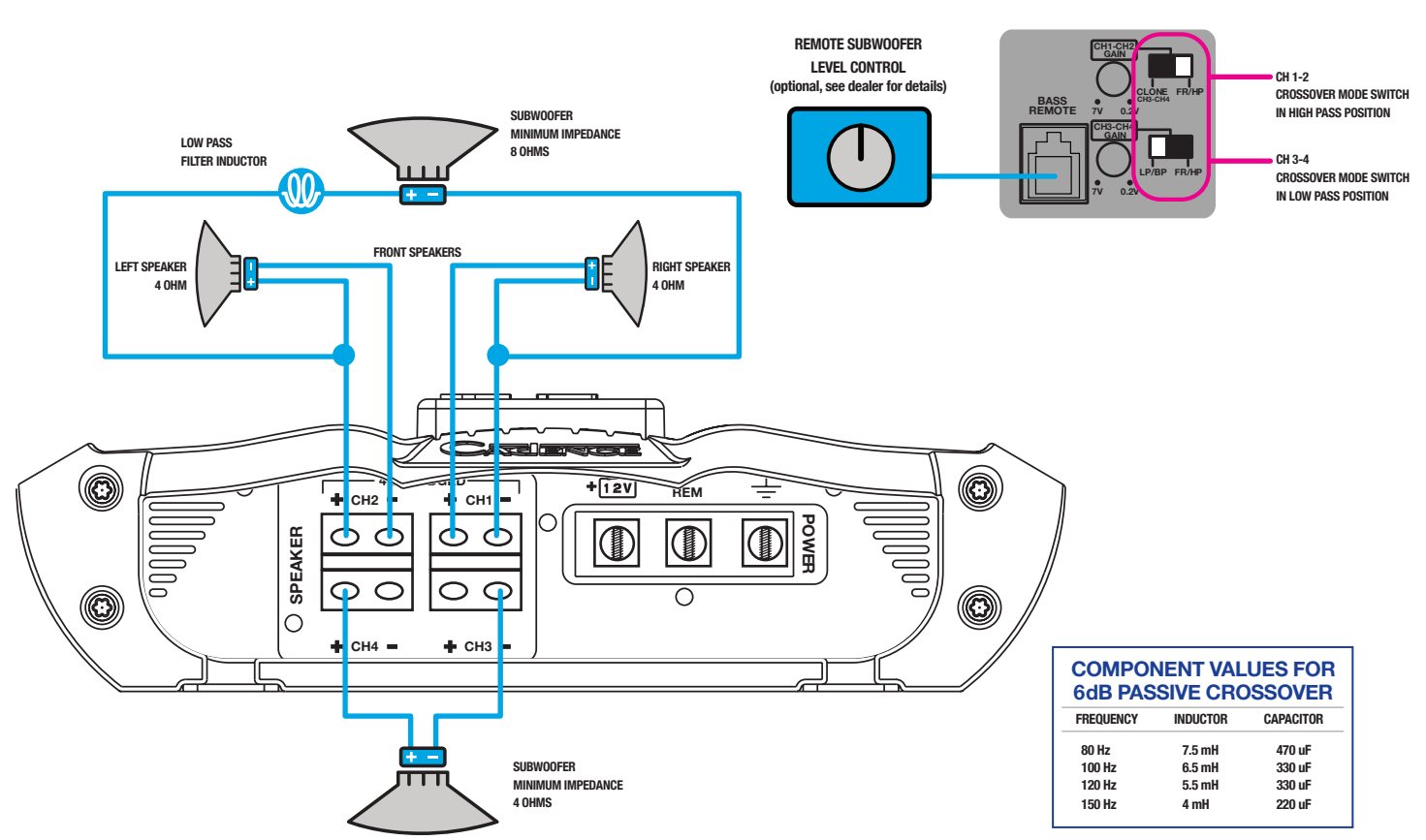

COMPONENT VALUES FOR 6dB PASSIVE CROSSOVER

FREQUENCY	INDUCTOR	CAPACITOR
80 Hz	7.5 mH	470 uF
100 Hz	6.5 mH	330 uF
120 Hz	5.5 mH	330 uF
150 Hz	4 mH	220 uF

4 CHANNEL WITH DUAL MIXED MONO CONFIGURATION

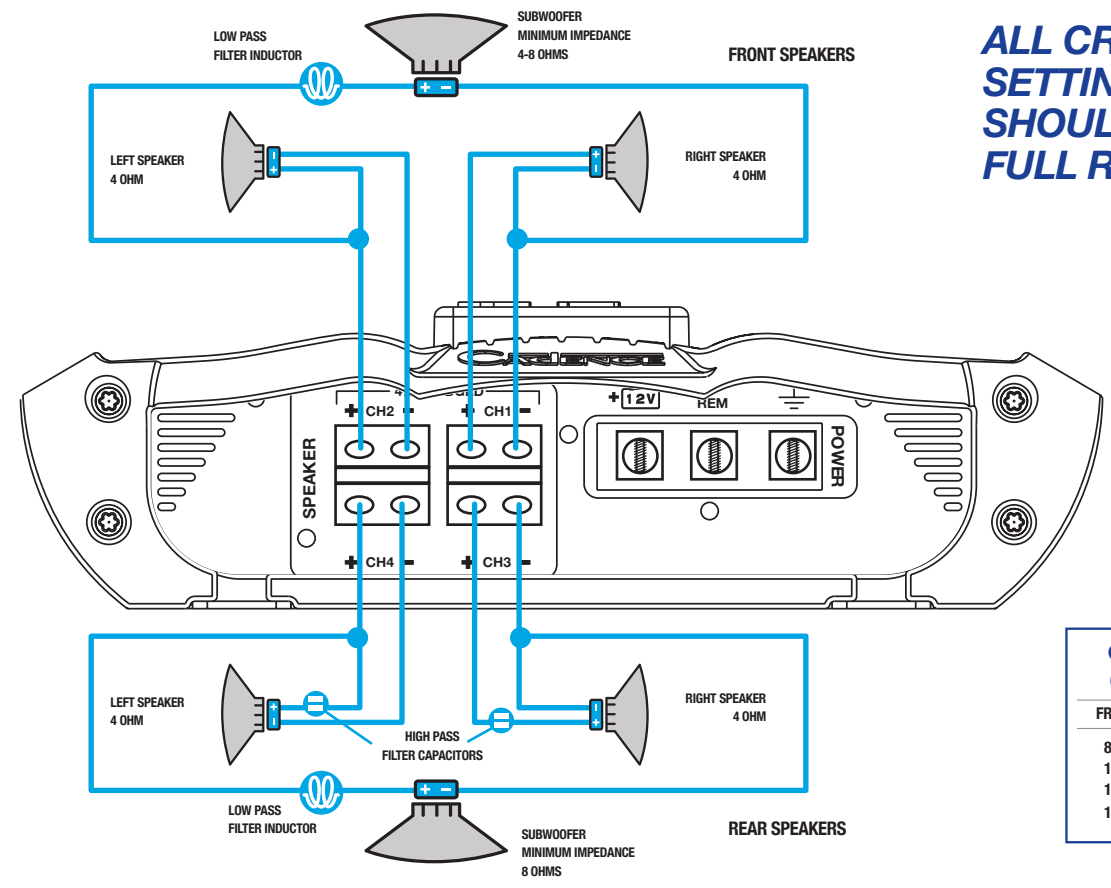

ALL CROSSOVER SETTINGS IN THIS MODE SHOULD BE SET TO FULL RANGE.

COMPONENT VALUES FOR 6dB PASSIVE CROSSOVER

FREQUENCY	INDUCTOR	CAPACITOR
80 Hz	7.5 mH	470 uF
100 Hz	6.5 mH	330 uF
120 Hz	5.5 mH	330 uF
150 Hz	4 mH	220 uF

2 CHANNEL AMPLIFIER 2 OHM / 4 OHM STEREO

2 CHANNEL AMPLIFIER 4 OHM BRIDGED

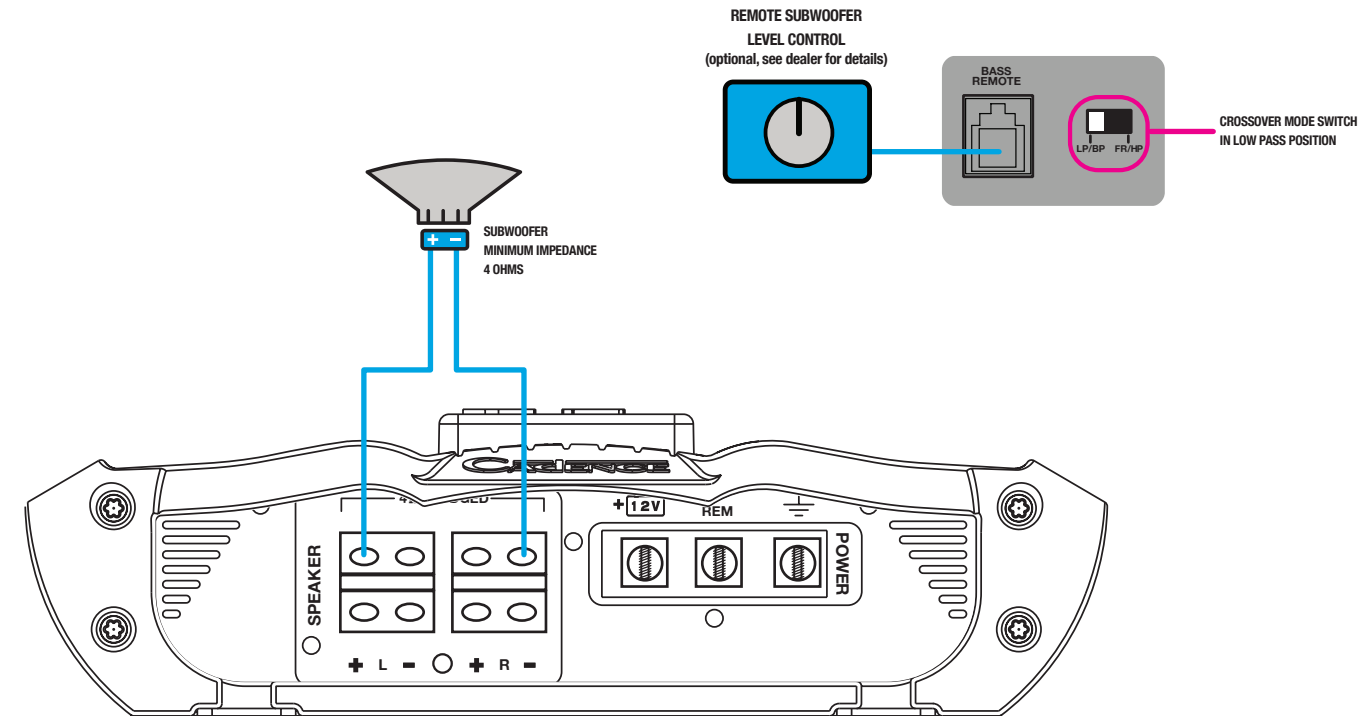
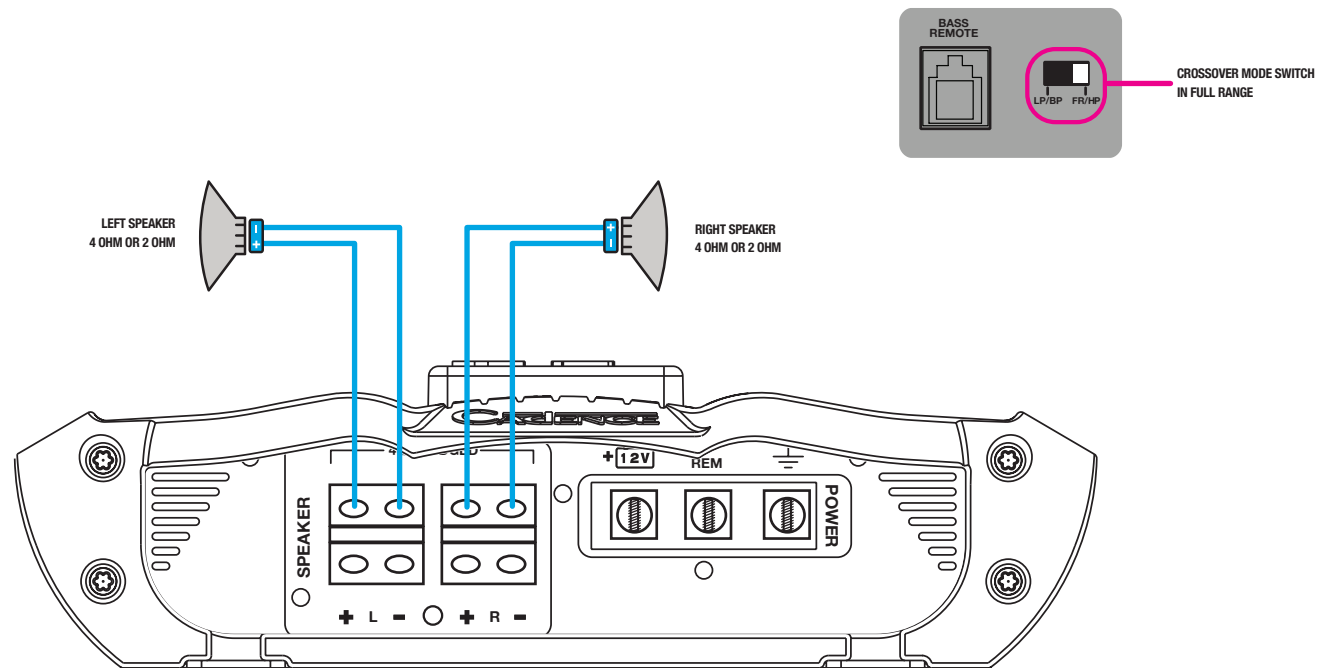

MONO BLOCK 2 OHM AMPLIFIERS

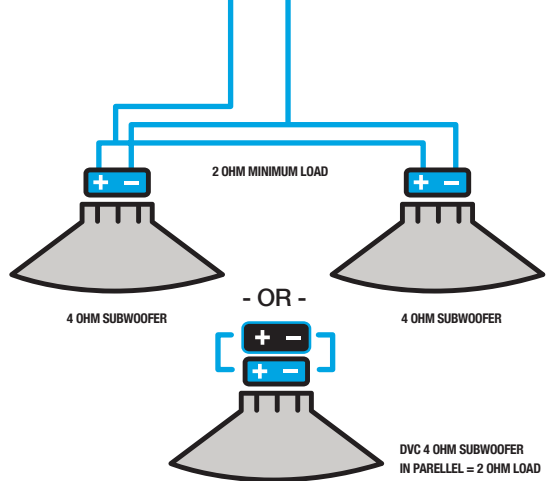
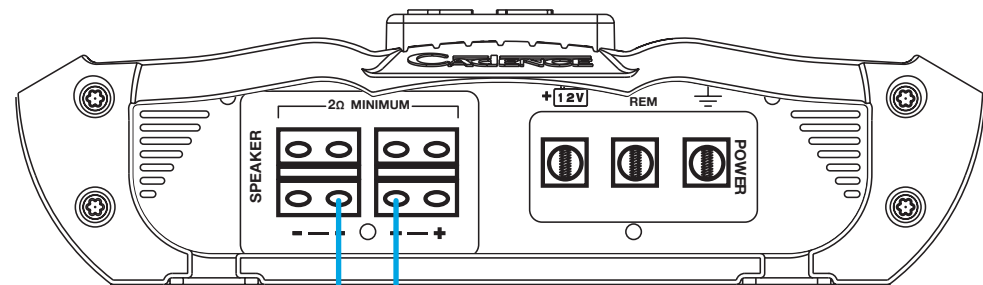

The D1600M is a 2 ohm mono block amplifier. No matter how many woofers you choose to wire up to this model, the final impedance should not fall below 2 ohms. Please see page 29 and 30 for various speaker impedance configurations.

CLASS D MONO BLOCK 1 OHM AMPLIFIER

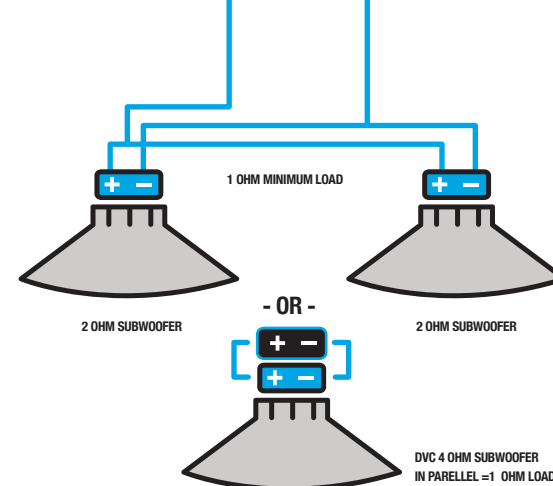
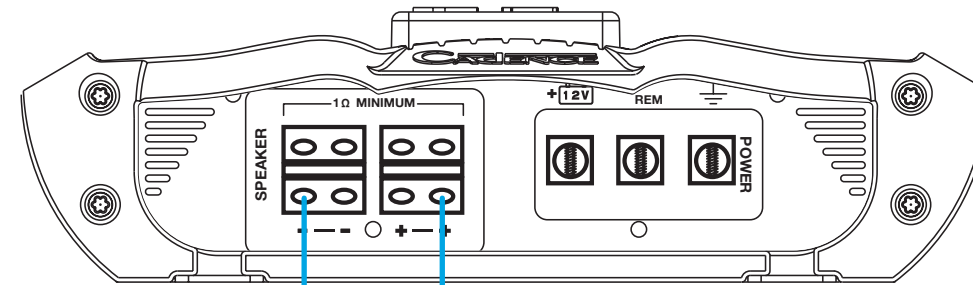

The D800, D1800M and D2500M are 1 ohm mono block Class D amplifiers. No matter how many woofers you choose to wire up to this amplifier the final impedance load should not fall below 1 ohm. Please see pages 29 and 30 for various speaker impedance configurations.

TWIN AMPLIFIER BRIDGING

You can only bridge 2 of the same amplifiers together. DO NOT bridge different models together.

MASTER

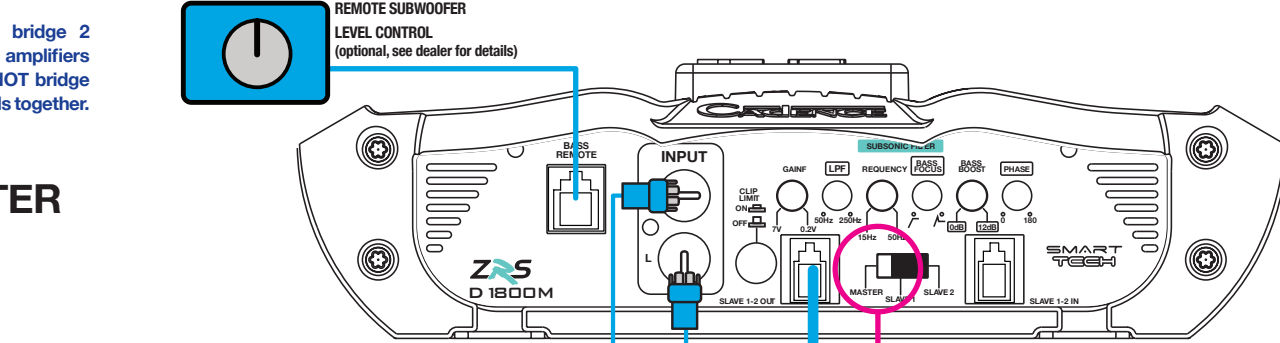

SLAVE

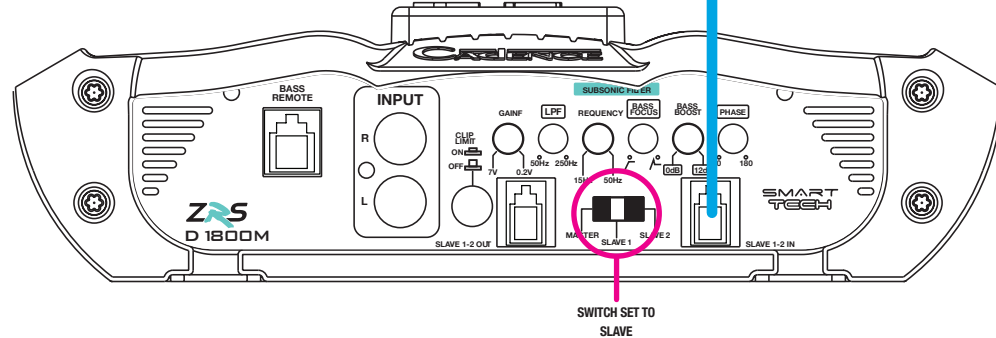

TWIN AMPLIFIER BRIDGING

The D1800M or D2500M can be bridged together for double the power output into a 2-ohm load. Though each amp is 1 ohm stable, when bridging amplifiers, you must bridge them to a 2 ohm load.

Input the head unit signal into the MASTER amplifier and set the Bridged Mode switch to Master. Use the supplied DATA CABLE to send the fully processed signal from the MASTER amplifier to the secondary SLAVE amplifier and set the Bridged Mode switch to Slave. Do not input any RCA signals into the Slave amplifier.

All crossover controls, Bass Drive, frequency settings, and subsonic filter settings will be controlled by the Master Amplifier including input gain levels. There is no need to gain match the two amplifiers, it will occur automatically. The remote dash bass control should be plugged in to the Master amplifier and it will control both amplifiers.

Make sure to use the supplied DATA CABLE for linking of the amplifiers and not the dash board bass remote cable or any other phone jack cable. If you misplace your cable, contact Cadence or your local dealer to procure a new one.

This same input/control system can be utilized when daisy chaining two amplifiers to two independent 1 ohm woofers as long as you don't bridge the two amplifiers outputs together.

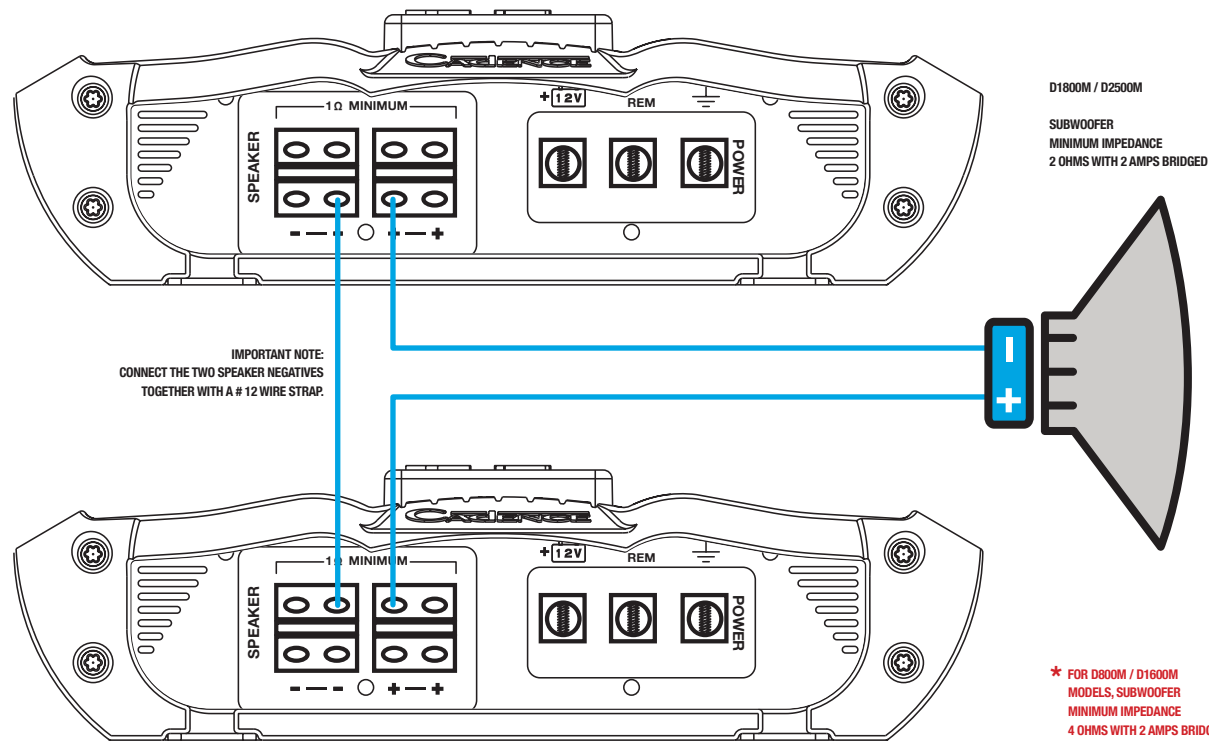

When bridging two D1800M OR D2500M amplifiers together, the final impedance load of the bridged amplifiers should be no lower than 2-ohms. Double power will occur at 2-ohms.

When bridging two D800M OR D1600M amplifiers together, the final impedance load of the bridged amplifiers should be no lower than 4-ohms. Double power will occur at 4-ohms.

Master amplifiers positive (+) speaker terminal should be wired to the positive terminal of the subwoofer. Slave amplifiers positive (+) speaker terminal should be wired to negative terminal of the subwoofer.

Now connect a heavy gauge wire (12 Gauge) between the negative (-) terminal of the Master amplifier and the Negative (-) terminal of the Slave amplifier.

Please see diagram on previous page for a detailed drawing.

When daisy chaining two amplifiers for independent woofers, wire up the the woofers as you would typically wire them when installing individual systems, even down to 1-ohm. By using the MASTER/SLAVE input configuration you gain the advantage of having one amplifiers' preamp section control both amplifiers, eliminating the need to gain match and crossover match your system between amplifiers.

DAISY CHAINING MULTIPLE AMPLIFIERS

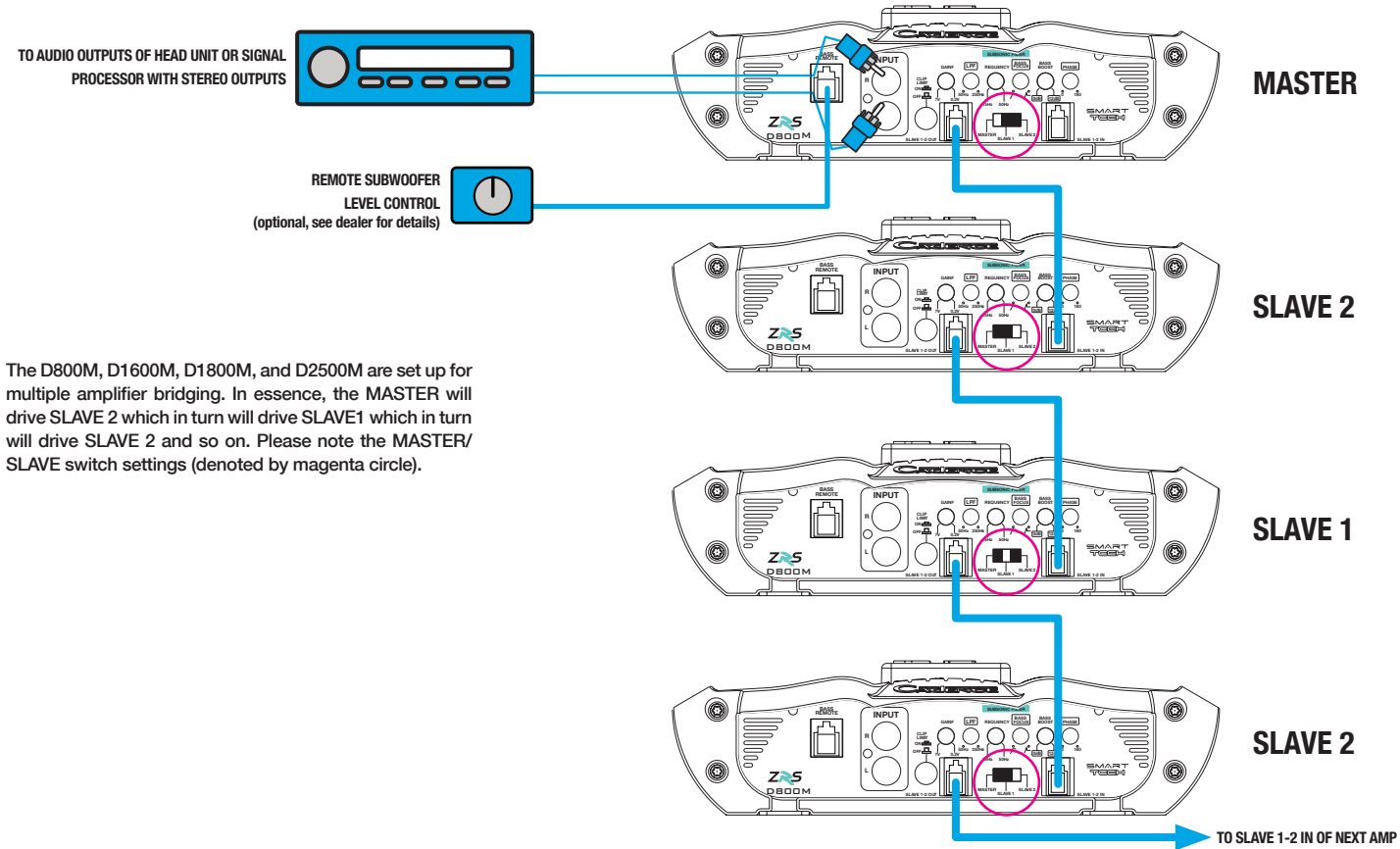

The D800M, D1600M, D1800M, and D2500M are set up for multiple amplifier bridging. In essence, the MASTER will drive SLAVE 2 which in turn will drive SLAVE1 which in turn will drive SLAVE 2 and so on. Please note the MASTER/SLAVE switch settings (denoted by magenta circle).

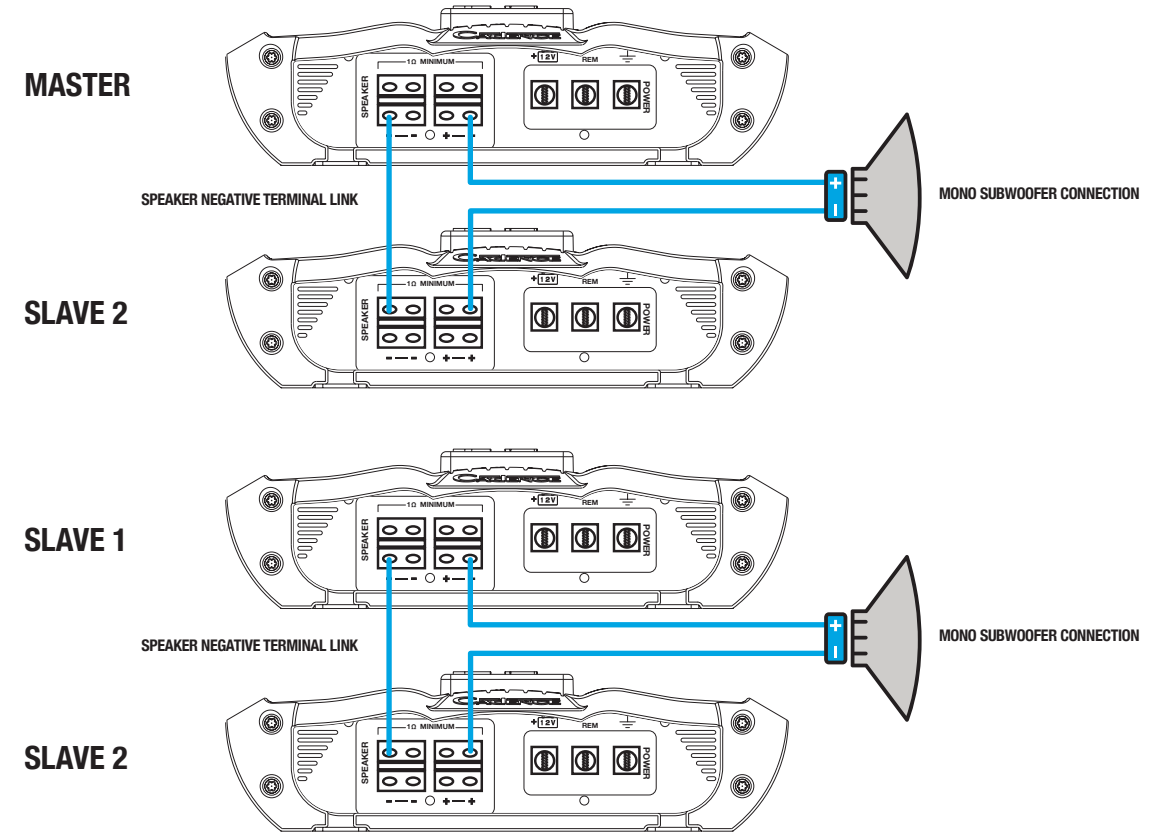

SPECIFICATIONS

D100.4

- RATED POWER: 100 WATTS RMS @ 4 OHM x 4
- RATED POWER: 150 WATTS RMS @ 2 OHM x 2
- MAXIMUM RMS POWER: 300W x 2 @ 4 OHM MONO BRIDGED
- MINIMUM THD AT RATED POWER: <0.01%
- FREQUENCY RESPONSE: 10Hz - 65KHz
- S/N RATIO: >100dB
- DAMPING FACTOR: >600 @ 100Hz
- DIMENSIONS (L x W x H): 2.4" x 12.4" x 8.6"

- HIGH SPEED MOFSET POWER SUPPLY
- BIPOLAR JAPANESE SANKEN OUTPUTS
- 16V CAPABLE POWER SUPPLIES
- 12 - 24 dB CROSSOVER CIRCUITRY
- BAND PASS CAPABLE
- BASS FOCUS WITH RUMBLE CONTROL
- ADJUSTABLE SUBSONIC FILTER

D250.2

- RATED POWER: 250 WATTS RMS @ 4 OHM x 4
- RATED POWER: 400 WATTS RMS @ 2 OHM x 2
- MAXIMUM RMS POWER: 800W x 1 @ 4 OHM MONO BRIDGED
- MINIMUM THD AT RATED POWER: <0.01%
- FREQUENCY RESPONSE: 10Hz - 65KHz
- S/N RATIO: >102dB
- DAMPING FACTOR: >1400 @ 100Hz
- DIMENSIONS (L x W x H): 2.4" x 16" x 8.6"

- HIGH SPEED MOFSET POWER SUPPLY
- BIPOLAR JAPANESE SANKEN OUTPUTS
- 16V CAPABLE POWER SUPPLIES
- 12 - 24 dB CROSSOVER CIRCUITRY
- BAND PASS CAPABLE
- BASS FOCUS WITH RUMBLE CONTROL
- ADJUSTABLE SUBSONIC FILTER

D350.2

- RATED POWER: 350 WATTS RMS @ 4 OHM x 4
- RATED POWER: 550 WATTS RMS @ 2 OHM x 2
- MAXIMUM RMS POWER: 1100W x 1 @ 4 OHM MONO BRIDGED
- MINIMUM THD AT RATED POWER: <0.01%
- FREQUENCY RESPONSE: 10Hz - 65KHz
- S/N RATIO: >102dB
- DAMPING FACTOR: >760 @ 100Hz
- DIMENSIONS (L x W x H): 2.4" x 16.3" x 8.6"

- HIGH SPEED MOFSET POWER SUPPLY
- BIPOLAR JAPANESE SANKEN OUTPUTS
- 16V CAPABLE POWER SUPPLIES
- 12 - 24 dB CROSSOVER CIRCUITRY
- BAND PASS CAPABLE
- BASS FOCUS WITH RUMBLE CONTROL
- ADJUSTABLE SUBSONIC FILTER

D800M

- RATED POWER: 500 WATTS RMS @ 2 OHM MONO
- RATED POWER: 800 WATTS RMS @ 1 OHM MONO
- TWIN AMPS BRIDGED: 1600W @ 4 OHM
- MINIMUM THD AT RATED POWER: <0.01%
- FREQUENCY RESPONSE: 10Hz - 500Hz
- S/N RATIO: >90dB
- DAMPING FACTOR: >200 @ 100Hz
- DIMENSIONS (L x W x H): 2.4" x 14" x 8.6"

- HIGH SPEED MOFSET POWER SUPPLY
- BIPOLAR JAPANESE SANKEN OUTPUTS
- 16V CAPABLE POWER SUPPLIES
- 12 - 24 dB CROSSOVER CIRCUITRY
- BAND PASS CAPABLE
- BASS FOCUS WITH RUMBLE CONTROL
- ADJUSTABLE SUBSONIC FILTER

NOTES

D1600M

- RATED POWER: 900 WATTS RMS @ 4 OHM MONO
- RATED POWER: 1600 WATTS RMS @ 2 OHM MONO
- TWIN AMPS BRIDGED: 3200W @ 4 OHM
- MINIMUM THD AT RATED POWER: <0.01%
- FREQUENCY RESPONSE: 10Hz - 500Hz
- S/N RATIO: >90dB
- DAMPING FACTOR: >200 @ 100Hz
- DIMENSIONS (L x W x H): 2.4" x 14.2" x 8.6"

- HIGH SPEED MOFSET POWER SUPPLY
- BIPOLAR JAPANESE SANKEN OUTPUTS
- 16V CAPABLE POWER SUPPLIES
- 12 - 24 dB CROSSOVER CIRCUITRY
- BAND PASS CAPABLE
- BASS FOCUS WITH RUMBLE CONTROL
- ADJUSTABLE SUBSONIC FILTER

D1800M

- RATED POWER: 1200 WATTS RMS @ 2 OHM MONO
- RATED POWER: 1800 WATTS RMS @ 1 OHM MONO
- TWIN AMPS BRIDGED: 3600W @ 2 OHM
- MINIMUM THD AT RATED POWER: <0.01%
- FREQUENCY RESPONSE: 10Hz - 500Hz
- S/N RATIO: >90dB
- DAMPING FACTOR: >300 @ 100Hz
- DIMENSIONS (L x W x H): 2.4" x 17" x 8.6"

- HIGH SPEED MOFSET POWER SUPPLY
- BIPOLAR JAPANESE SANKEN OUTPUTS
- 16V CAPABLE POWER SUPPLIES
- 12 - 24 dB CROSSOVER CIRCUITRY
- BAND PASS CAPABLE
- BASS FOCUS WITH RUMBLE CONTROL
- ADJUSTABLE SUBSONIC FILTER

D2500M

- RATED POWER: 1600 WATTS RMS @ 2 OHM MONO
- RATED POWER: 2500 WATTS RMS @ 1 OHM MONO
- TWIN AMPS BRIDGED: 5000W @ 2 OHM
- MINIMUM THD AT RATED POWER: <0.01%
- FREQUENCY RESPONSE: 10Hz - 500Hz
- S/N RATIO: >90dB
- DAMPING FACTOR: >150 @ 100Hz
- DIMENSIONS (L x W x H): 2.4" x 17.7" x 8.6"

- HIGH SPEED MOFSET POWER SUPPLY
- BIPOLAR JAPANESE SANKEN OUTPUTS
- 16V CAPABLE POWER SUPPLIES
- 12 - 24 dB CROSSOVER CIRCUITRY
- BAND PASS CAPABLE
- BASS FOCUS WITH RUMBLE CONTROL
- ADJUSTABLE SUBSONIC FILTER

SPEAKER WIRING CHART

4 X DUAL VC 8 OHM SPEAKERS WITH SERIES VOICE COILS, ALL IN PARALLEL

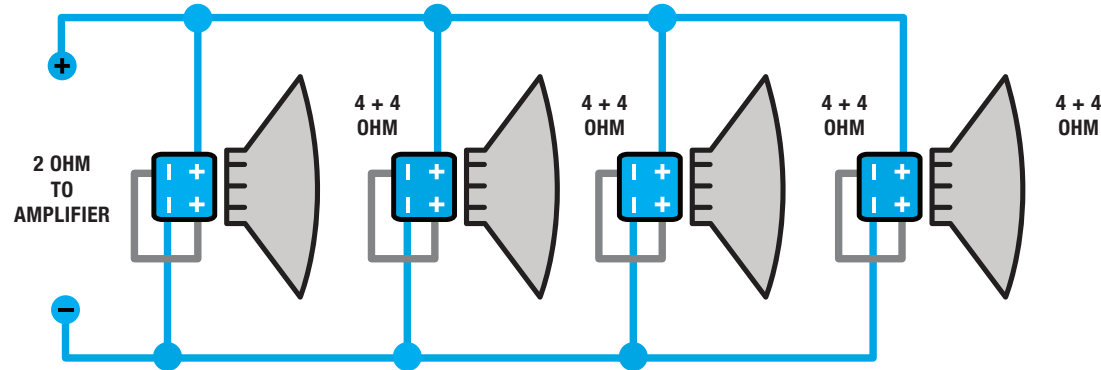

SERIES: SINGLE VOICE COIL SPEAKERS

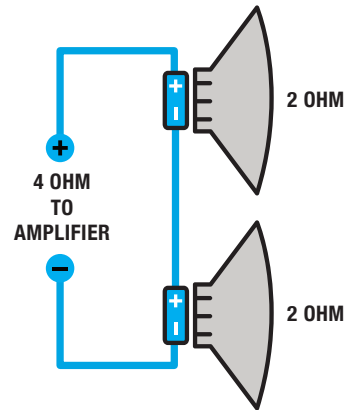

PARALLEL: SINGLE VOICE COIL SPEAKERS

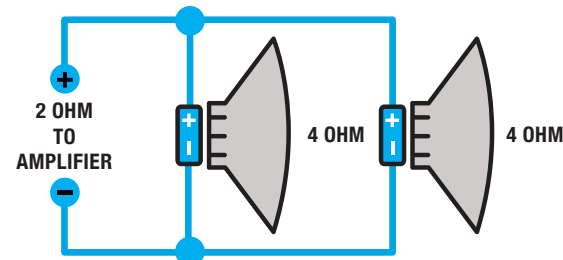

SERIES: DUAL VOICE COIL SPEAKERS

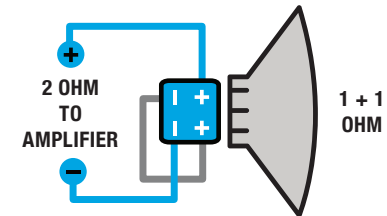
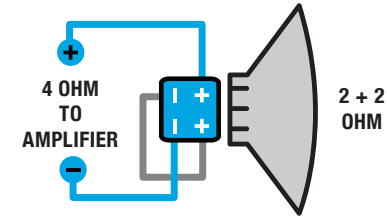
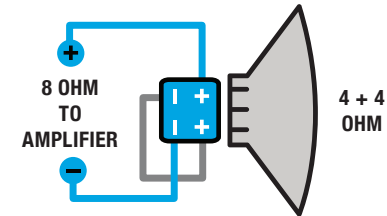

PARALLEL: DUAL VOICE COIL SPEAKERS

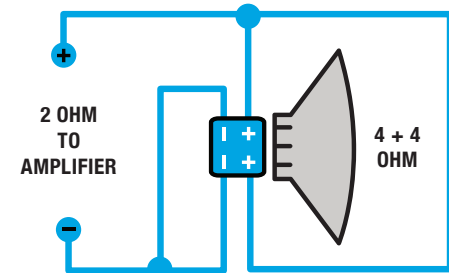

2 X DUAL VC 2 OHM SPEAKERS WITH SERIES VOICE COILS, ALL IN PARALLEL

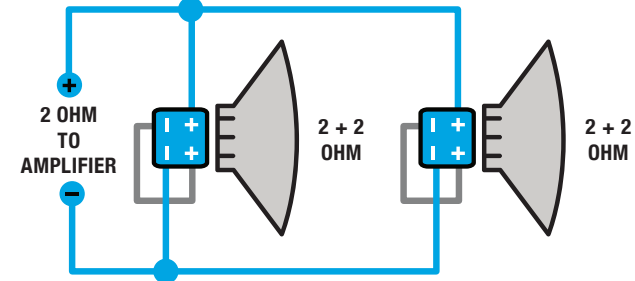

Please note that the minimum impedance load for single Cadence United Amplifiers is 2 ohm stereo and 4 ohm mono bridged.

Lower impedance loads will cause overheating and may damage the amplifiers.

Do not mix different impedance speakers in series and / or parallel combinations, as unequal power sharing and acoustic outputs will result.

// Due to constant product improvements, these specifications are subject to change without notice.
Though we tried our best to insure that this manual is free and clear of errors please don't hold us responsible for printing errors. //

Copyright by Cadence Acoustics LTD.