

Kramer Electronics, Ltd.

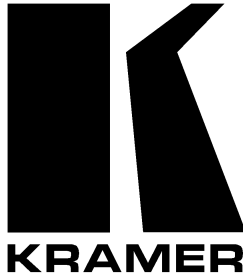

USER MANUAL

Models:

VS-162AV, 16x16 Audio-Video Matrix Switcher

VS-162AVRCA, 16x16 Audio-Video Matrix Switcher

Contents

1	Introduction	1
2	Getting Started	1
3	Overview	2
4	Summary of how to Operate a Single Machine	3
5	Your Audio-Video Matrix Switcher	4
6	Installing the Audio-Video Matrix Switcher	8
6.1	Configuring a Stand Alone Switcher	8
6.1.1	Connecting a Balanced Stereo Audio Input / Output (VS-162AV)	9
6.1.2	Connecting an Unbalanced Stereo Audio Input / Output (VS-162AV)	9
6.2	Assembling a System of Interconnected Switchers	10
6.3	Dipswitch Settings	11
6.3.1	Setting the MACHINE #	11
6.3.2	Understanding the SYSTEM Mode	12
6.3.3	Understanding the SLAVE Mode	13
6.4	Connecting a Control Interface	13
6.4.1	Connecting the RS-232 Control Interface	14
6.4.1.1	Connecting 2 Units using a Null-modem Adapter	15
6.4.1.2	Connecting 2 Units without using a Null-modem Adapter	15
6.4.1.3	PC DB9 COM Port Connection to a Unit with a Null-modem Adapter	15
6.4.1.4	PC DB9 COM Port Connection to a Unit with no Null-modem Adapter	15
6.4.1.5	PC DB25 COM Port Connection to a Unit	16
6.4.2	Connecting the RS-485 Control Interface	16
6.5	Configuring the Sync	18
6.6	Connecting the KEYBOARD EXTENSION	19
7	Operating Your Audio-Video Matrix Switcher	20
7.1	Startup Display	20
7.2	Using the Front Panel Buttons	20
7.2.1	Choosing the Audio-Follow-Video or Breakaway Mode	21
7.2.1.1	Setting the Breakaway Mode	21
7.2.1.2	Setting the Audio-Follow-Video Mode	21
7.2.2	Confirming Settings	22
7.2.2.1	Toggling between the AT ONCE and CONFIRM Modes	22
7.2.3	Switching	23
7.2.3.1	Switching one Input to one Output	23
7.2.3.2	Switching several Inputs to several Outputs	24
7.2.3.3	Switching one Input to all Outputs	25
7.2.4	Clearing	26
7.2.4.1	Clearing an Output	26
7.2.4.2	Clearing several Outputs	27
7.2.4.3	Clearing all Outputs	28
7.2.5	Storing and Recalling Setups	29
7.2.5.1	Storing Setups	29
7.2.5.2	Recalling Setups	30

8	MENU Commands Sequence	31
8.1	Locking and Unlocking the Front Panel	32
8.2	Choosing the Follow-System or Breakaway-From-System Mode	33
8.3	Choosing the SWITCHING METHOD Setting	35
8.3.1	Understanding the SWITCHING METHOD Settings	35
8.3.2	Configuring a SWITCHING METHOD	36
8.4	Choosing the extended Keyboard Setting	37
8.5	Setting the STORE/RECALL KEYBOARD Mode	37
8.6	Choosing what to INDICATE	38
8.7	Choosing the COMMUNICATION Setting	39
8.8	Setting the IR REMOTE Control	40
8.9	Choosing the AUTO STORE Current SETUP	41
8.10	Identifying the MACHINE	41
8.11	Choosing the initial RESET	42
9	Flash Memory Upgrade	43
9.1	Connecting the PC to the RS-232 Port	43
9.2	Upgrading Firmware	43
10	Technical Specifications	46
11	Communication Protocol	46

Figures

Figure 1: Default Dipswitch Setup on a Single Machine	3
Figure 2: VS-162AV 16x16 Audio-Video Matrix Switcher	5
Figure 3: VS-162AVRCA 16x16 Audio-Video Matrix Switcher	6
Figure 4: Configuring the VS-162AV as a Stand Alone Switcher	9
Figure 5: Connecting a Balanced Stereo Audio Input # 1	9
Figure 6: Connecting an Unbalanced Stereo Audio Input # 1	9
Figure 7: Assembling a System of Interconnected Switchers	10
Figure 8: Rear Panel Dipswitches	11
Figure 9: Connecting a PC to 4 Units	14
Figure 10: Connecting a PC (with a 25-pin connector) without a Null-modem Adapter	16
Figure 11: RS-485 Connector PINOUT	16
Figure 12: Connecting the RS-485 Connectors	17
Figure 13: An RS-485 Control Interface Setup	18
Figure 14: Keyboard Extension (EXT. KEYS) Connector	19
Figure 15: Default Startup Status Display Sequence	20
Figure 16: Sequence of MENU Commands	31
Figure 17: Choosing the MTX (SYNC from Matrix) Setting	36
Figure 18: Choosing what to INDICATE	38
Figure 19: Machine Identification	42

Tables

Table 1: Quick Reference Operating Guide for a Single Machine	4
Table 2: Front Panel Unit Features	7
Table 3: Rear Panel VS-Unit Features	7
Table 4: Dipswitch Definitions	11
Table 5: Machine # Dipswitch Settings	12
Table 6: Summary of Basic IR-1 Setups	40
Table 7: Summary of Basic IR-1 Operations	40
Table 8: Technical Specifications of VS-162AV / VS-162AVRCA	46
Table 9: Hex Table for the VS-162AV / VS-162AVRCA Audio-Video Matrix Switcher	47

1 Introduction

Welcome to Kramer Electronics (since 1981): a world of unique, creative and affordable solutions to the infinite range of problems that confront the video, audio and presentation professional on a daily basis. In recent years, we have redesigned and upgraded most of our line, making the best even better! Our 350-plus different models now appear in 8 Groups¹, which are clearly defined by function. Congratulations on purchasing your Kramer: **VS-162AV** *16x16 Audio-Video Matrix Switcher*, and/or **VS-162AVRCA** *16x16 Audio-Video Matrix Switcher*, which are ideal for the following typical applications:

- Any professional system requiring outstanding value in a 16x16 matrix
- Production and duplication facilities
- Rental/staging applications
- Security, CCTV, and home theater systems

The package includes the following items:

- **VS-162AV** *16x16 Audio-Video Matrix Switcher* or **VS-162AVRCA** *16x16 Audio-Video Matrix*
- Power cord
- Windows®-based control software
- Null-modem adapter
- This user manual²
- Kramer **RC-IR1** Infra-Red Remote Control Transmitter³ (including the required battery and a separate user manual²)

2 Getting Started

We recommend that you:

- Unpack the equipment carefully and save the original box and packaging materials for possible future shipment
- Review the contents of this user manual
- Use Kramer high performance high resolution cables⁴

1 GROUP 1: Distribution Amplifiers; GROUP 2: Video and Audio Switchers, Matrix Switchers and Controllers; GROUP 3: Video, Audio, VGA/XGA Processors; GROUP 4: Interfaces and Sync Processors; GROUP 5: Twisted Pair Interfaces; GROUP 6: Accessories and Rack Adapters; GROUP 7: Scan Converters and Sealers; and GROUP 8: Cables and Connectors

2 Download up-to-date Kramer user manuals from the Internet at: <http://www.kramerelectronics.com>

3 Previously known as the IR-1 / IR-1-01

4 The complete list of Kramer cables is on our Web site at <http://www.kramerelectronics.com>

3 Overview

The **VS-162AV** is a high performance 16x16 vertical interval matrix switcher for composite video signals on BNC connectors, and balanced stereo audio signals on detachable terminal block connectors. The **VS-162AVRCA** is a high performance 16x16 vertical interval matrix switcher for composite video signals on BNC connectors, and unbalanced stereo audio signals on RCA connectors.

A main advantage of the **VS-162AV / VS-162AVRCA** is that it forms part of the series of 16x16 matrix switchers that includes, but is not limited to, **VS-1616SDI** (a 16x16 digital Video Matrix Switcher), **VS-1616AD** (a 16x16 digital audio matrix switcher), **VS-1616V** (a 16x16 analog video matrix switcher), **VS-1616A** (a 16x16 analog balanced stereo audio matrix switcher), and **VS-162V** (a 16x16 video matrix switcher).

In particular, the **VS-162AV / VS-162AVRCA**:

- Has multiple SYNC options that make it appropriate for a wide range of applications with glitch-free transitions. It produces glitch-free transitions, when sources share a common reference sync¹
- Offers excellent video performance, which ensures that it remains transparent in almost any video application
- Video bandwidth extends to well over 90 MHz, making it suitable for all video applications while audio bandwidth and levels conform to broadcast specifications for audio applications

In addition the **VS-162AV / VS-162AVRCA**:

- Can be configured into a Kramer multi-signal switcher system including digital and analog video, digital and analog audio, and RS-422 control switchers
- When integrated in a system, all units switch in true audio-follow-video mode
- Both audio-follow-video and breakaway modes are available
- Recalls up to 60 configuration setups via the non-volatile memory and provides for an unlimited quantity of setups when using the Kramer control software on your PC
- Includes a user-friendly LCD display (making operation even easier)
- With its FLASH memory, lets you upgrade to the latest Kramer firmware version via Internet download
- Comes with a choice of protocol format: hexadecimal or ASCII

Control the **VS-162AV / VS-162AVRCA**:

- Using the front panel buttons

¹ As it switches during the vertical interval

- Remotely, by RS-485 or RS-232 serial commands transmitted by a touch screen system, PC, or other serial controller
- Remotely, from the Kramer **RC-IR1** Infra-Red Remote Control Transmitter¹
- Via external dry-contact push buttons

Note: From here onward, “unit” refers to the “VS-162AV / VS-162AVRCA”.
On the VS-162AV, the audio signals are balanced stereo signals on detachable terminal block connectors. On the VS 162AVRCA, the audio signals are unbalanced stereo signals on RCA connectors.

To achieve the best performance:

- Connect only good quality connection cables, thus avoiding interference, deterioration in signal quality due to poor matching, and elevated noise levels (often associated with low quality cables)
- Avoid interference from neighboring electrical appliances that may adversely influence signal quality and position your unit in a location free from moisture and away from excessive sunlight and dust

4 Summary of how to Operate a Single Machine

By default, the *16x16 Audio-Video Matrix Switcher* is setup for use as a single machine. This means that it is:

- A 16x16 composite video switcher and a 16x16 balanced stereo audio switcher (**VS-162AV**)/16x16 unbalanced stereo audio switcher (**VS-162AVRCA**), set to function by default, in the audio-follow-video mode
- Switched during the vertical interval of the external reference

In particular, be sure that the dipswitches are set as Figure 1 illustrates (see section 6.3 for further details):

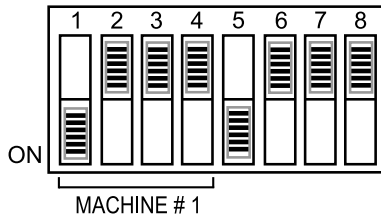

Figure 1: Default Dipswitch Setup on a Single Machine

To operate a single machine, see Table 1.

¹ Previously known as the IR-1 / IR-1-01

Table 1: Quick Reference Operating Guide for a Single Machine

To perform this command:	Press:
Set breakaway mode ¹	VIDEO
Set breakaway mode ²	AUDIO
Set audio-follow-video mode ³	AFV
Connect an input with an output	OUT #; IN #
Clear (disconnect) a specific output	OUT #; OFF
Clear (disconnect) all outputs	ALL; OFF
Connect all outputs to a specific input	ALL; IN #
Store a setup	STO; OUT #; TAKE
Recall a setup	RCL; OUT #; TAKE
Lock front panel	MENU; TAKE
Unlock front panel	TAKE; TAKE
Change default setup	Press the Menu button several times until you reach the appropriate Menu setup command and follow the instructions

5 Your Audio-Video Matrix Switcher

Figure 2 illustrates the front and rear panels of the **VS-162AV**. Figure 3 illustrates the front and rear panels of the **VS-162AVRCA**. Table 2 and Table 3 define the front and rear panels of the unit.

1 All operations and the LCD MATRIX Display relate to the video channel (independently from audio)

2 All operations and the LCD MATRIX Display relate to the audio channel (independently from video)

3 All operations and the LCD MATRIX Display relate to both the video and the audio channels. Audio channels follow the video channels

Your Audio-Video Matrix Switcher

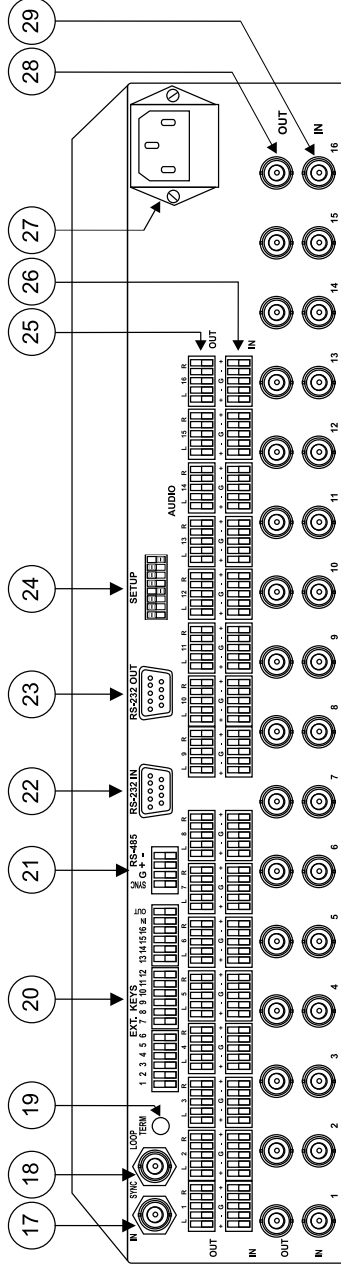
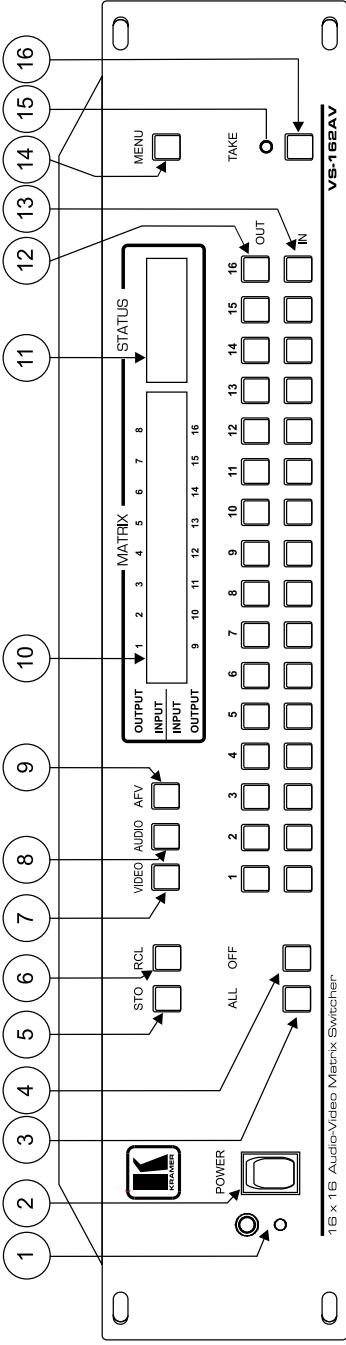

Figure 2: VS-162AV 16x16 Audio-Video Matrix Switcher

Your Audio-Video Matrix Switcher

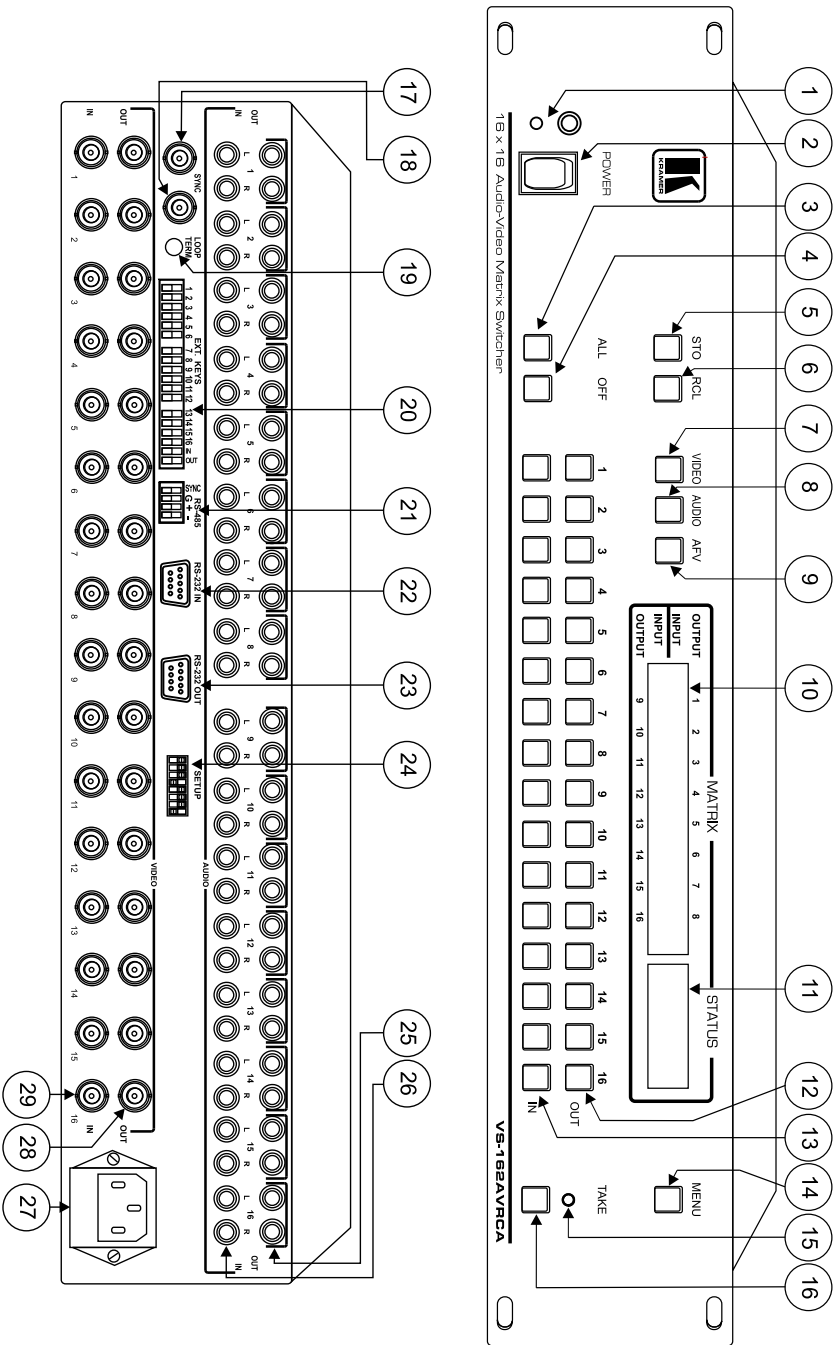

Figure 3: VS-162AVRCA 16x16 Audio-Video Matrix Switcher

Your Audio-Video Matrix Switcher

Table 2: Front Panel Unit Features

#	Feature	Function
1	IR Receiver	The red LED is illuminated when receiving signals from the Kramer Infra-red remote control transmitter
2	POWER Switch	Illuminated switch supplying power to the unit
3	ALL Button	Pressing ALL followed by an INPUT button, connects that input to all outputs
4	OFF Button	An OFF-OUT combination disconnects that output from the inputs; an OFF-ALL combination disconnects all the outputs
5	STO Button	Stores the current setting in the non-volatile memory
6	RCL Button	Recalls a setup from the non-volatile memory
7	VIDEO Button	When pressed ¹ actions relate to video independently from audio
8	AUDIO Button	When pressed ² actions relate to audio independently from video
9	AFV Button	When pressed actions relate to video and audio channels. Audio channels follow the video channels, and the AFV button is illuminated
10	LCD MATRIX Display ³	Displays the selected input(s) switched to the output(s) (above or below the corresponding OUTPUT label) and user interface messages
11	LCD STATUS Display ³	Displays the matrix status (input to output connections)
12	OUT Buttons	Select the output to which the input is switched
13	IN Buttons	Select the input to switch to the output
14	MENU Button	Selects the programming commands to setup the switcher
15	TAKE LED	Shows the current TAKE button mode
16	TAKE Button	Used to confirm and complete setup and switching

Table 3: Rear Panel Unit Features

#	Feature	Function
17	SYNC IN BNC Connector	Connect to the external video sync source
18	LOOP BNC Connector	Connect to the SYNC IN connector on the next unit
19	TERM Button	Press to terminate at 75Ω or release for looping (push in to terminate the sync line. Push out when the sync line extends to another unit)
20	EXT. (extension) KEYS Terminal Block Connectors	Connect to an external keyboard (remote unit)
21	RS-485 Detachable Terminal Block Port	PINS # 1 and # 2 are for vertical sync and Ground connection, and PINS # 3 and # 4 are for RS 485
22	RS-232 IN DB 9F Port	Connect to the PC or the Remote Controller ⁴
23	RS-232 OUT DB 9M Port	Connect to the RS-232 IN DB9F port of the next unit in the daisy-chain connection
24	SETUP Dipswitches	Dipswitches for setup of the unit
25	OUT Connectors ⁵	Connect to the audio acceptors ⁶
26	IN Connectors ⁵	Connect to the audio sources ⁶
27	Power Connector with Fuse	AC connector enabling power supply to the unit
28	OUT BNC Connectors	Connect to the video acceptors
29	IN BNC Connectors	Connect to the video sources

1 The VIDEO button is illuminated when the video breakaway mode is selected

2 The AUDIO button is illuminated when the audio breakaway mode is selected

3 In sections 7.2.5 and 8, the word “Displays” refers to the LCD MATRIX and STATUS Displays

4 If the unit is not the first unit in the line, connects to the RS-232 OUT DB 9F port of the previous unit in the line

5 Terminal blocks on the VS-162AV; RCA connectors on the VS-162AVRCA

6 Balanced on the VS-162AV, unbalanced on the VS-162AVRCA

6 Installing the Audio-Video Matrix Switcher

To install the unit, connect the following¹ to the rear panel, as required:

- Power cord
- Video input and output cables
- Audio input and output cables
- Control Interface cables between switcher units, or PC (or other controller), as section 6.4 describes
- Set the dipswitches, as section 6.3 describes
- Set the system variables using the MENU function, as section 8 describes

Using the unit and/or other 16x16 matrix switchers in the series², you can assemble the following kinds of systems:

- A stand alone switcher (see section 6.1)
- A system of interconnected switchers (see section 6.2)
- A multi-channel switcher (see section 6.3.3)

6.1 Configuring a Stand Alone Switcher

By default, a single **VS-162AV** unit is configured for:

- Composite video with 16 inputs and 16 outputs on BNC connectors, **and**
- Balanced stereo audio³ with 16 inputs and 16 outputs on detachable terminal block connectors, as section 6.1.1 describes (to configure for unbalanced⁴ stereo audio, see section 6.1.2)

Configure your **VS-162AV** unit as a stand alone switcher, as Figure 4 illustrates:

1 Switch OFF the power on each device before connecting it to your unit

2 Including the VS-1616SDI (a 16x16 digital video matrix switcher), the VS-1616AD (a 16x16 digital audio matrix switcher), the VS-1616V (a 16x16 analog video matrix switcher), the VS-1616A (a 16x16 analog balanced stereo audio matrix switcher), and the VS-162V (a 16x16 video matrix switcher)

3 The VS-162AVRCA (unlike the VS-162AV) is configured for unbalanced stereo audio with 16 inputs and 16 outputs on RCA connectors

4 However, for an unbalanced stereo audio input, the output will always be half of the input signal. For example, if the input is 6dB, the output will be 0dB

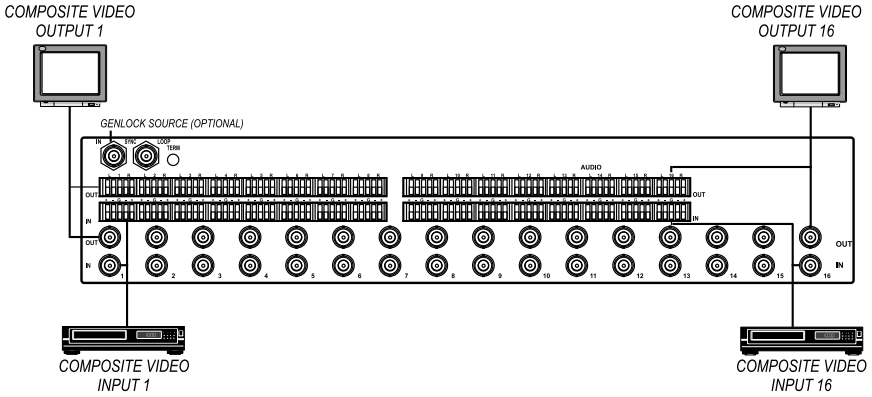

Figure 4: Configuring the VS-162AV as a Stand Alone Switcher

6.1.1 Connecting a Balanced Stereo Audio Input / Output (VS-162AV)

Figure 5 illustrates a balanced stereo audio input # 1:

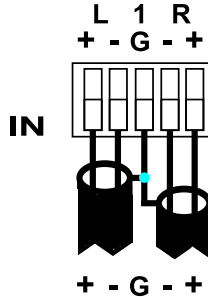

Figure 5: Connecting a Balanced Stereo Audio Input # 1

6.1.2 Connecting an Unbalanced Stereo Audio Input / Output (VS-162AV)

Figure 6 illustrates an unbalanced stereo audio input # 1:

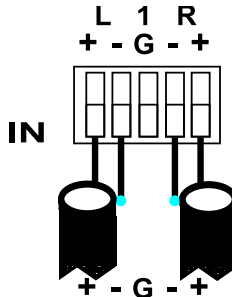

Figure 6: Connecting an Unbalanced Stereo Audio Input # 1

6.2 Assembling a System of Interconnected Switchers

A major advantage of the unit is that it belongs to the series of 16x16 matrix switchers and, as such, can interconnect with other switchers in the series. This series includes, but is not limited to, **VS-1616SDI** (a 16x16 digital Video Matrix Switcher), **VS-1616AD** (a 16x16 digital audio matrix switcher), **VS-1616V** (a 16x16 analog video matrix switcher), **VS-1616A** (a 16x16 analog balanced stereo audio matrix switcher), and **VS-162V** (a 16x16 video matrix switcher).

The block diagram in Figure 7 illustrates how to assemble an interconnected varied-format 16x16 series switcher that consists of a 16x16 audio-video matrix switcher, a 16x16 digital video matrix switcher, and a 16x16 digital audio matrix switcher. Each switcher has a unique MACHINE #. In Figure 7, the 16x16 audio-video matrix switcher is MACHINE # 1, the 16x16 digital video matrix switcher is MACHINE # 2 and the 16x16 digital audio matrix switcher is MACHINE # 3. Control of the system is via the MACHINE #'s.

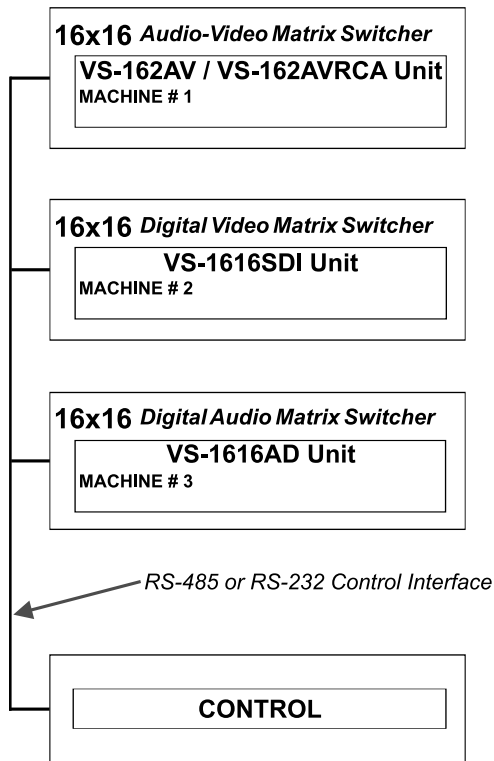

Figure 7: Assembling a System of Interconnected Switchers

Refer to section 6.3 for details of how to set the dipswitches, and to section 6.4 for details of how to control this group of interconnected varied-format 16x16 series switchers, and other configurations.

6.3 Dipswitch Settings

Configure the unit by setting the 8 dipswitches as Figure 8 and Table 4 define:

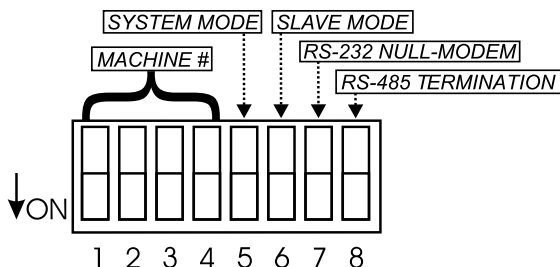

Figure 8: Rear Panel Dipswitches

Table 4: Dipswitch Definitions

Dipswitch #	Function:
1-4	Set the MACHINE # (see Table 5 in section 6.3.1)
5	Enables (ON) or disables (OFF) the <i>Follow-SYSTEM</i> mode
6	Enables (ON) or disables (OFF) the <i>SLAVE</i> mode in a multi-channel configuration
7	Disables use of a null modem adapter ¹ with RS-232 OFF = RS-232 connection via a null modem adapter ON = RS-232 connection without a null modem adapter
8	RS-485 termination for first and last machine = ON (RS-485 line terminates with 110Ω); for others = OFF (RS-485 line is open)

6.3.1 Setting the MACHINE

To control a unit via RS-232 or RS-485, each unit has to be identified via its unique MACHINE #.

Set the MACHINE #² on a unit according to Table 5.

A valid MACHINE # is from 1 to 15.

¹ See section 6.4.1

² When using a single unit, set the unit to MACHINE # 1

Table 5: Machine # Dipswitch Settings

MACHINE #	DIPSWITCH			
	1	2	3	4
1	ON	OFF	OFF	OFF
2	OFF	ON	OFF	OFF
3	ON	ON	OFF	OFF
4	OFF	OFF	ON	OFF
5	ON	OFF	ON	OFF
6	OFF	ON	ON	OFF
7	ON	ON	ON	OFF
8	OFF	OFF	OFF	ON
9	ON	OFF	OFF	ON
10	OFF	ON	OFF	ON
11	ON	ON	OFF	ON
12	OFF	OFF	ON	ON
13	ON	OFF	ON	ON
14	OFF	ON	ON	ON
15	ON	ON	ON	ON

6.3.2 Understanding the SYSTEM Mode

The terms *audio-follow-video*¹ and *audio breakaway*² are well known. Sometimes signals other than audio signals need to switch simultaneously and at other times, need to switch independently. For example:

- Non-linear editing systems, that sometimes combine video with analog audio and at other times combine video with digital audio
- Duplication systems, that make Master tapes from programs with different formats: composite analog, component analog and component digital

DIP 5 defines whether the unit communicates with other switchers via a common control line.

You can set **DIP 5 OFF** to disable the *Follow-SYSTEM* mode in Stand alone switcher applications³.

You **must set DIP 5 ON** to enable the *Follow-SYSTEM* mode in an interconnected varied-format switcher application⁴.

Refer to section 8.2 for a description of the MENU's *Follow-SYSTEM* and *Breakaway-from- SYSTEM* modes.

1 Video and the audio channels switch simultaneously in the same way

2 Audio channels switch independently from the video channels

3 See section 6.1

4 See section 6.2

6.3.3 Understanding the SLAVE Mode

The SLAVE mode is only used for the multi-channel video switcher configuration, for example, when joining together two units. Two units could be configured as a 16x16 s-Video (Y/C) with 4-channel stereo audio.

One unit is used as the Master, and the other unit is the Slave. The Slave always follows the Master. In the example the first unit is the Master (with DIP 6 set OFF disabling the Slave mode) and the second unit is the Slave (with DIP 6 set ON enabling the Slave mode).

On the Slave unit, the MATRIX and STATUS Displays do not illuminate and the STATUS Display shows this message:

Keyboard LOCKED

However, the STATUS Display on the Slave unit dynamically shows¹ all changes made from the Master unit (which are implemented also on the Slave unit).

Front panel control is via the Master unit, on which the front panel buttons are unlocked and both the MATRIX and STATUS Displays illuminate.

6.4 Connecting a Control Interface

Connect a control interface (RS-232 or RS-485) unless operating a unit as a stand alone unit without any control device (that is, with control from the front panel or IR port, and not via a remote controller or a PC).

The control interface must be identical on each switcher in the series of 16x16 matrix switchers; either RS-232 or RS-485. One control interface suffices. Do not use both RS-232 and RS-485 control interfaces in the same configuration. For example, in an interconnected varied-format 16x16 switcher application², if the switcher that connects to the PC connects via the RS-232 control interface, each switcher must interconnect via the RS-232 control interface and not via the RS-485 control interface.

Choose the RS-232 control interface, for a range of up to about 25 meters used for a point-to-point connection.

Choose the RS-485 control interface, to operate the switcher for a distance of up to 1000 meters.

¹ Albeit with an LCD Display that does not illuminate

² See section 6.2

6.4.1 Connecting the RS-232 Control Interface

Connect several switchers (from the series of 16x16 matrix switchers) and the control unit in an RS-232 daisy chain arrangement, with or without using a Null-modem adapter, as Figure 9 illustrates.

The RS-232 daisy chain switcher arrangement is transparent. This lets you arrange the switchers (from the series of 16x16 matrix switchers) according to your requirements, and not according to a fixed sequence dependent on the MACHINE # and/or MACHINE ADDRESS #.

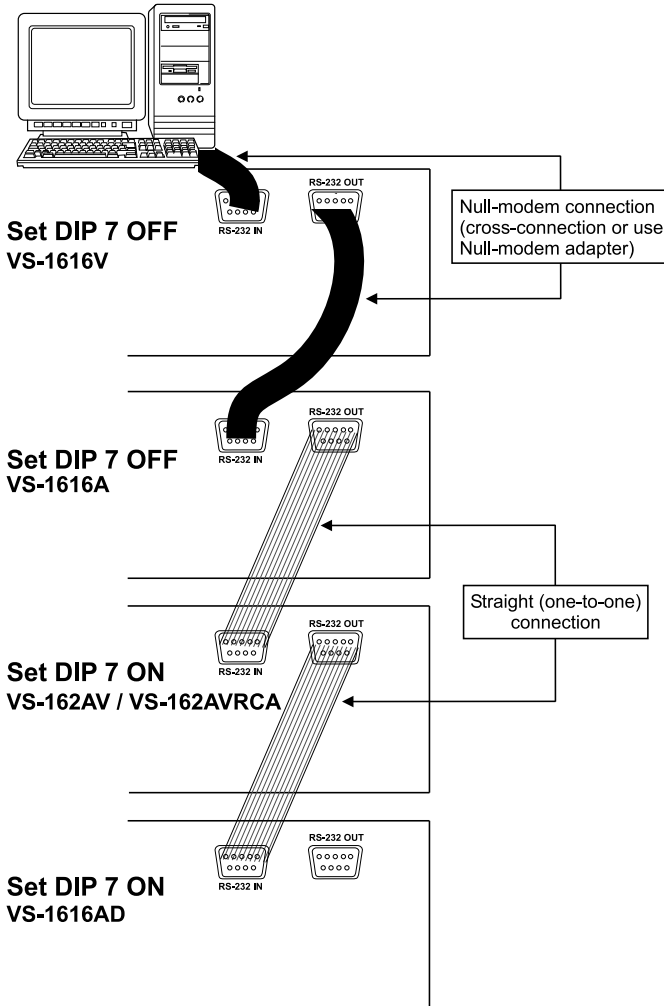

Figure 9: Connecting a PC to 4 Units

You can connect any of the following:

- 2 units, using a Null-modem adapter (see section 6.4.1.1) or without using a Null-modem adapter (see section 6.4.1.2)
- The PC's DB9 COM port to a unit with a Null-modem adapter (see section 6.4.1.3) or without a Null-modem adapter (see section 6.4.1.4)
- The PC's DB25 COM port to a unit without a Null-modem adapter (see section 6.4.1.5)

6.4.1.1 Connecting 2 Units using a Null-modem Adapter

To connect 2 units, **using a Null-modem adapter** provided with the machine (default):

1. Connect a flat cable¹ between the RS-232 OUT DB9 port on the first unit and the Null-modem adapter that attaches to the RS-232 IN DB9 port on the second unit.
2. On the second unit, set **DIP 7 OFF** (enabling Null-modem adapter use).

6.4.1.2 Connecting 2 Units without using a Null-modem Adapter

To connect 2 units, **without using a Null-modem adapter**:

1. Connect a flat cable¹ between the RS-232 OUT DB9 port on the first unit and the RS-232 IN DB9 port on the second unit.
2. On the second unit, set **DIP 7 ON** (disabling Null-modem adapter use²).

6.4.1.3 PC DB9 COM Port Connection to a Unit with a Null-modem Adapter

To connect the PC's DB9 COM port to a unit, **using a Null-modem adapter**:

1. Connect a flat cable¹ between the PC's DB9 COM port and the Null-modem adapter that attaches to the RS-232 IN DB9 port on the unit.
2. Set **DIP 7 OFF** (enabling Null-modem adapter use²) on the unit.

6.4.1.4 PC DB9 COM Port Connection to a Unit with no Null-modem Adapter

To connect the PC's DB9 COM port to a unit, **without using a Null-modem adapter**:

1. Connect a flat cable¹ between the PC's DB9 COM port and the RS-232 IN DB9 port on the unit.
2. Set **DIP 7 ON** (disabling Null-modem adapter use²) on the unit.

¹ Straight one-to-one uncrossed connections with at least the 3 wires pins # 2, # 3 and # 5

² See section 6.3

6.4.1.5 PC DB25 COM Port Connection to a Unit

To connect the PC's DB25 COM port to a unit:

1. Connect the PC's DB25 COM port to the RS-232 IN DB9 port on the unit, as Figure 10 illustrates:

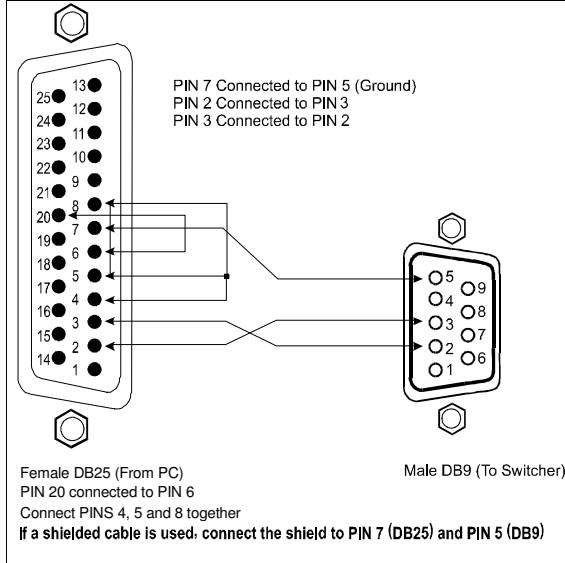

Figure 10: Connecting a PC (with a 25-pin connector) without a Null-modem Adapter

2. Set DIP 7 ON (disabling Null-modem adapter use¹) on the unit.

6.4.2 Connecting the RS-485 Control Interface

Figure 11 defines the RS-485 connector PINOUT for external RS-485 control. The RS-485 connector is also used (if required) for vertical sync:

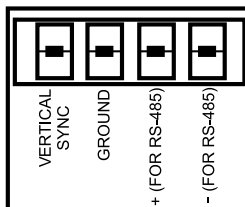

Figure 11: RS-485 Connector PINOUT

¹ Straight one-to-one uncrossed connections with at least the 3 wires pins # 2, # 3 and # 5

To connect an RS-485 connector on one unit to an RS-485 connector on one or more other switchers (from the series of 16x16 matrix switchers), as Figure 12 illustrates:

1. Connect the “+” PIN on the first unit to the “+” PIN on the second unit or other unit
2. Connect the “-” PIN on the first unit to the “-” PIN on the second unit or other unit
3. If shielded cable is used for an RS-485 connection, connect the shield to the Ground PIN.

For details about how to configure the vertical sync (if required), refer to section 6.5 and Figure 17 in section 8.3.1.

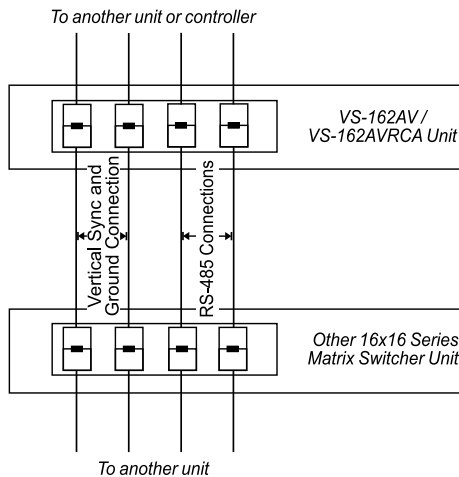

Figure 12: Connecting the RS-485 Connectors

Figure 13 illustrates the RS-485 line that connects:

- Between the unit, the **VS-1616SDI** and the **VS-1616AD** units
- To the PC via a Kramer Tools **VP-43xl Interface Converter** (connect the PC’s DB 9 COM port to the “RS-232 in” DB9F port on the **VP-43xl**. Next, connect the RS-485 port on the **VP-43xl** to the RS-485 ports on the unit, **VS-1616SDI** and **VS-1616AD** units by connecting the “A” terminal of the **VP-43xl** to the “+” terminals of the switchers, and “B” to “-” terminals)

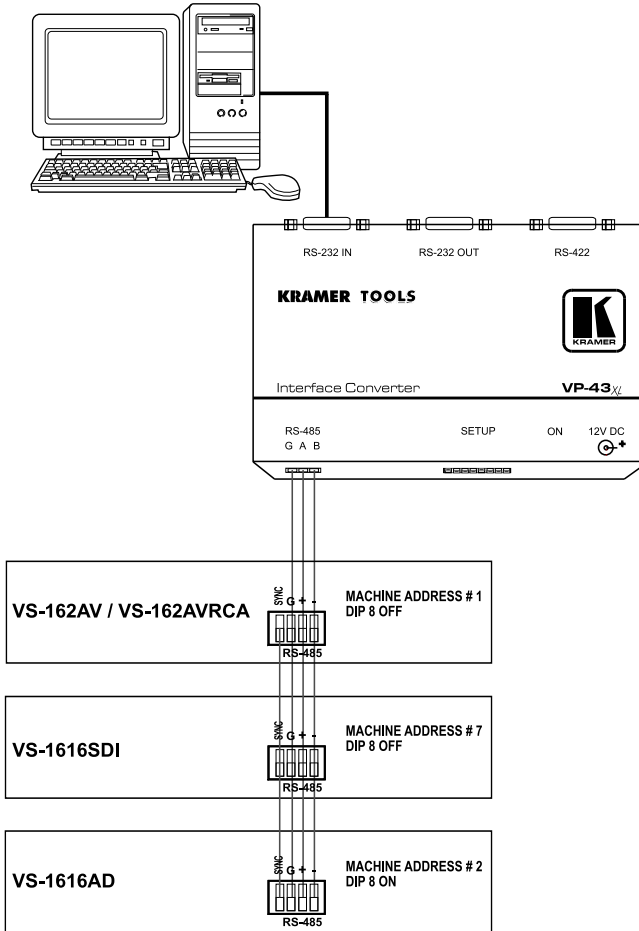

Figure 13: An RS-485 Control Interface Setup

6.5 Configuring the Sync

On the unit, you can select one of the following, as the sync input:

- EXTERNAL (“sync in” BNC connector)
- INPUT # 1 BNC connector
- MTX (Sync from Matrix) RS-485 Terminal Block connector, when using multiple machines¹

¹ Refer to section 8.3.1

Configure the sync via the SWITCHING METHOD Menu command setting¹. When setting up multiple machines, linking a common sync to all the machines may be necessary to facilitate simultaneous vertical interval switching.

Usually, the easiest method is to choose the sync source from the first machine and then connect all the terminal block connectors.

In this case, set the first machine to select the sync source from the external sync connector or from the INPUT # 1 connector. This sync is now available to the other machines via the RS-485 terminal block connector, as Figure 11 and Figure 12 illustrate. Select the MTX sync on the other machines that receive that sync.

6.6 Connecting the KEYBOARD EXTENSION

Connecting dry contact-closure switches to the Keyboard Extension (*EXT. KEYS*) connector enables you to route an input to an output by remote control from a distance of up to 1000 meters. These IN and OUT keys are expandable². Figure 14 illustrates how to connect the Keyboard Extension (*EXT. KEYS*):

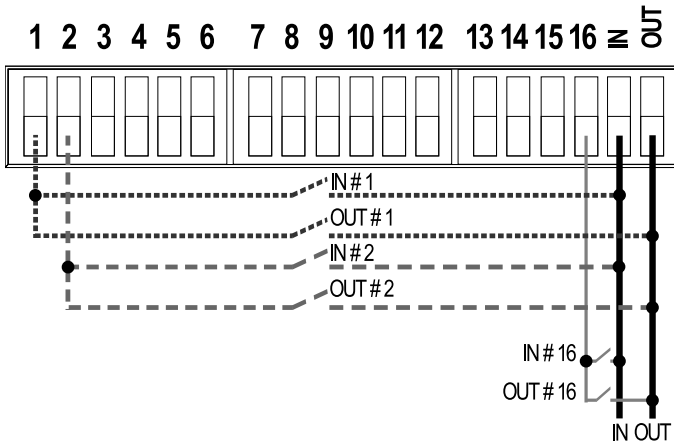

Figure 14: Keyboard Extension (*EXT. KEYS*) Connector

To use the Keyboard Extension, activate the extended KEYBOARD setting Menu command, as section 8.4 describes.

¹ Refer to section 8.3

² Add an unlimited number of push buttons to the existing keys (in parallel) by attaching one end of the push button to the corresponding number and the other end to the IN or OUT terminal

7 Operating Your Audio-Video Matrix Switcher

Operate your unit via:

- The front panel buttons (as this section describes)
- RS-232 or RS-485 serial commands transmitted by a touch screen system, PC¹, or other serial controller
- Kramer **RC-IR1** Infra-Red Remote Control Transmitter²
- Dry contact-closure switches connected to the Keyboard Extension

7.1 Startup Display

After switching on the power, the *MATRIX* and *STATUS*³ displays show the following screen:

MATRIX								STATUS								
OUTPUT	1	2	3	4	5	6	7	8								
INPUT	KRAMER ELECTRONICS, Ltd								Software							
INPUT	VS-162AV AUDIO/VIDEO MATRIX								Ver. 1.5							
OUTPUT	9	10	11	12	13	14	15	16								

Figure 15: Default Startup Status Display Sequence

7.2 Using the Front Panel Buttons

You can switch video/audio signals in the *BREAKAWAY* or *AUDIO-FOLLOW-VIDEO* modes (see section 7.2.1), and you can work in the *AT ONCE* or *CONFIRM* modes (see section 7.2.2).

You can switch (see section 7.2.3) and clear (see section 7.2.4):

- One input to one output
- Several inputs to several outputs
- One input to all outputs

¹ For instructions on using Kramer Windows®-based Control Software, refer to the separate user manual (included on the CD-ROM in .pdf format), Kramer Control Software

² Previously known as the IR-1 / IR-1-01

³ Version 1.5 is shown in the Status Display as an example; text in the Matrix Display may vary (according to machine settings)

7.2.1 Choosing the Audio-Follow-Video or Breakaway Mode

You can switch video/audio signals in one of 2 ways, either:

- *BREAKAWAY*, in which video and audio channels switch independently; **or**
- *AUDIO-FOLLOW-VIDEO* (AFV) in which all operations relate to both the video and the audio channels¹

7.2.1.1 Setting the Breakaway Mode

To set the *BREAKAWAY* mode, either:

- Press the VIDEO (for video control only) button

If the VIDEO button illuminates, all operations and the LCD MATRIX and STATUS Displays relate to Video; **or**

- Press the AUDIO (for audio control only) button

If the AUDIO button illuminates, all operations and the LCD MATRIX and STATUS Displays relate to Audio

7.2.1.2 Setting the Audio-Follow-Video Mode

To set the Audio-follow-video (AFV) mode²:

1. Press the AFV button.
2. If the audio and video configurations are the same, the AFV button illuminates. All operations and the LCD MATRIX and STATUS Displays relate to both the video and the audio channels.
3. If the audio configuration differs from the video configuration, each of the following will occur simultaneously:
 - The Audio and Video buttons will blink in a fast alternating cycle
 - The TAKE LED will blink
 - In the MATRIX Display, digits that represent different audio/video configurations will blink alternately(For example, the MATRIX Display would show as the input for output 10, the blinking, alternating digits 01 and 02, if IN 1 was routed to OUT 10 for video, and IN 2 was routed to OUT 10 for audio)
4. Press the TAKE button to confirm the modification (reconfiguring the audio according to the video).

¹ Audio and video connections are the same and switch at the same moment at the beginning of the sync

² Be aware that all audio configurations that differ from the video configurations will be lost when returning to the audio breakaway mode after the AFV mode. To store an audio configuration setup, see section 7.2.5

7.2.2 Confirming Settings

Choose to work in the *AT ONCE* mode or the *CONFIRM* mode:

In the *AT ONCE* (default¹) mode:

- Actions require no user confirmation
- Execution is immediate
- No protection is offered against changing an action in error

In the *CONFIRM* mode²:

- You have an optional method to help avoid making a mistake
- Every action requires user confirmation
- Execution is delayed³ until the user confirms the action
- Protection is offered to prevent erroneous switching
- You can key-in several actions and then confirm them by pressing the TAKE button once, to simultaneously switch several outputs

7.2.2.1 Toggling between the AT ONCE and CONFIRM Modes

To toggle between the *AT ONCE* (default) mode and the *CONFIRM* mode, press the TAKE button.

In *CONFIRM* mode: Actions require user confirmation and the TAKE LED lights.

In *AT ONCE* mode: Actions do not require user confirmation and the TAKE LED does not light.

When the TAKE LED blinks:

- You cannot toggle between the *AT ONCE* and *CONFIRM* modes
- You can execute the previous action, by pressing the TAKE button
- You can cancel the previous action, by pressing a non-relevant button (for example, the MENU button)

¹ For all actions except storing/recalling setups

² The *CONFIRM* mode is the default for storing/recalling setups (see section 8.5)

³ Failure to press the TAKE button within about 30 seconds (the Timeout) will abort the action

7.2.3 Switching

You can switch:

- One input to one output (see section 7.2.3.1)
- Several inputs to several outputs (see section 7.2.3.2)
- One input to all outputs (see section 7.2.3.3)

7.2.3.1 Switching one Input to one Output

Pressing an OUT-IN combination when your unit operates in the AT ONCE mode implements the switch immediately.

To switch one input to one output (AT ONCE mode):

1. Press the appropriate OUT button.
The MATRIX Display shows the 2 blinking digits, representing the present input number connected to that specific output¹. If the present output is clear, the 2 blinking digits 00 appear in the MATRIX Display. The STATUS Display shows the message:

out # x

Where x is the output number

2. Press the appropriate IN button.
The output switches to the input and the MATRIX Display shows the Input # instead of the blinking digits.
The STATUS Display momentarily shows the message:

**out # x
from in # y**

Where x is the output number and y is the input number

Pressing an OUT-IN combination when your unit operates in the CONFIRM mode (and the TAKE LED is lit), requires user confirmation.

To switch one input to one output (CONFIRM mode):

1. Repeat step 1 above.
2. Press the appropriate IN button.
The MATRIX Display shows the 2 blinking digits, representing the input number and the TAKE LED blinks.
The STATUS Display shows² the message:

1 For example, pressing OUT button 9 shows the blinking digits 01 if input 1 was previously routed to OUT 9

2 Continuously, within the limit of the timeout (approximately 30 seconds)

out # x
from in # y

Where x is the output number and y is the input number

3. Press the TAKE button to confirm the action.
The output switches to the input and the TAKE LED lights.

7.2.3.2 Switching several Inputs to several Outputs

In the *AT ONCE* mode, you need to execute each OUT-IN combination separately (see section 7.2.3.1). When switching many inputs to many outputs it is recommended to toggle to the CONFIRM mode.

In the CONFIRM mode you can key-in several actions and then confirm them by pressing the TAKE button once (simultaneously switching several inputs to several outputs).

To switch several inputs to several outputs in the CONFIRM mode (the TAKE LED is lit), do the following:

1. Press the appropriate OUT button.
The MATRIX Display shows the 2 blinking digits, representing the previous input number for that specific output¹. If the previous input is clear, the 2 blinking digits 00 appear in the MATRIX Display.
The STATUS Display shows the message:

out # x

Where x is the output number

2. Press the appropriate IN button.
The MATRIX Display shows the 2 blinking digits, representing the input number and the TAKE LED blinks.
The STATUS Display shows² the message:

out # x
from in # y

Where x is the output number and y is the input number

3. Press the second appropriate OUT button, repeating step 1 above.
4. Press the appropriate³ IN button, repeating step 2 above.

¹ For example, pressing OUT button 9 shows the blinking digits 01 if input 1 was previously routed to OUT 9

² Continuously, within the limit of the timeout (approximately 30 seconds)

³ That corresponds with the second OUT button

5. Continue with this OUT-IN button sequence, pressing the appropriate OUT and IN buttons, as required. You can also combine an OUT-OFF or OFF-OUT combination with this sequence.
6. After completing the sequence, press the TAKE button to confirm the actions.
The inputs switch to the respective outputs, as the MATRIX Display shows (no digits blink) and the TAKE LED lights.

7.2.3.3 Switching one Input to all Outputs

To switch one input to all the outputs (in the AT ONCE mode):

1. Press the ALL button.
The MATRIX Display shows all the sets of 2 blinking digits (each representing the present input number for that respective output) blinking simultaneously.
The STATUS Display shows the message:

all OUTs

2. Press the appropriate IN button.
This input switches to all the outputs and the MATRIX Display shows the identical non-blinking 2 digits (representing that input number).

To switch one input to all the outputs (in the CONFIRM mode, (the TAKE LED is lit)):

1. Repeat steps 1 and 2 above.
The TAKE LED blinks.
2. Press the TAKE button to confirm the action.
The selected input switches to all the outputs and the TAKE LED lights.
The MATRIX Display shows the identical 2 non-blinking digits (representing that input number) for all outputs.

7.2.4 Clearing¹

You can clear (delete):

- One output (see section 7.2.4.1)
- Several outputs (see section 7.2.4.2)
- All outputs (see section 7.2.4.3)

7.2.4.1 Clearing an Output

To clear an output (in the AT ONCE mode):

1. Press the appropriate OUT button.
The MATRIX Display shows the 2 blinking digits, representing the present input number for that specific output². If the present input is clear, the 2 blinking digits 00 appear in the MATRIX Display.
The STATUS Display shows the message:

out # x

Where x is the output number

2. Press the OFF button³.
The input is cleared and the MATRIX Display does not show any Input # in its place.
The STATUS Display momentarily shows the message:

**out # x
reset**

Where x is the output number

To clear an output (in the CONFIRM mode (the TAKE LED is lit)):

1. Repeat step 1 above.
2. Press the OFF button³.
The MATRIX Display shows the 2 blinking digits 00 instead of the previous 2 blinking digits and the TAKE LED blinks.
The STATUS Display shows⁴ the message:

**out # x
reset**

Where x is the output number

1 "Clearing" means disconnecting the output from any of the inputs, and leaving it disconnected

2 For example, pressing OUT button 9 shows the blinking digits 01 if input 1 was previously routed to OUT 9

3 You can press the OFF button first, and then an OUT button (the order is irrelevant)

4 Continuously, within the limit of the timeout (approximately 30 seconds)

3. Press the TAKE button to confirm the action.
The input is cleared and the TAKE LED lights. The MATRIX Display does not show any Input # in its place.

7.2.4.2 Clearing several Outputs

To clear several outputs (in the AT ONCE mode):

1. Press the appropriate OUT button.
The MATRIX Display shows the 2 blinking digits, representing the present input number for that specific output¹. If the present output is clear, the 2 blinking digits 00 appear in the MATRIX Display.
The STATUS Display shows the message:

out # x

Where x is the output number

2. Press the OFF button.
The output is cleared and the MATRIX Display does not show any Input # in its place.
The STATUS Display momentarily shows the message:

**out # x
reset**

Where x is the output number

To clear several outputs (in the CONFIRM mode (the TAKE LED is lit)):

1. Repeat step 1 above.
2. Press the OFF button.
The MATRIX Display shows the 2 blinking digits 00 instead of the previous 2 blinking digits and the TAKE LED blinks.
The STATUS Display shows² the message:

**out # x
reset**

Where x is the output number

3. Press the second appropriate OUT button, by repeating step 1 above.
4. Repeat step 2 above.

¹ For example, pressing OUT button 9 shows the blinking digits 01 if input 1 was previously routed to OUT 9

² Continuously, within the limit of the timeout (approximately 30 seconds)

5. Continue with this OUT-OFF button sequence, pressing the appropriate OUT buttons and the OFF, as required.
The MATRIX Display shows the sets of 2 blinking digits, representing the present input number for each specific output.
6. After completing the sequence, press the TAKE button to confirm the actions.
The inputs are cleared and the TAKE LED lights. The MATRIX Display does not show any Input # in its place.

7.2.4.3 Clearing all Outputs

To clear all outputs (in the AT ONCE mode):

1. Press the ALL button.
The MATRIX Display shows all the sets of 2 blinking digits (each representing the present input number connected to that respective output) blinking simultaneously.
The STATUS Display shows the message:

all OUTs

2. Press the OFF button¹.
All the outputs are cleared and the MATRIX Display momentarily shows the message:

**Reset ALL connections
!!!!**

To switch one input to all the outputs (in the CONFIRM mode (the TAKE LED is lit)):

1. Repeat step 1 above.
2. Press the OFF button¹.
The TAKE LED blinks and the MATRIX Display shows the message:

**Reset ALL ?
Press TAKE to execute**

3. Press the TAKE button to confirm.
All the outputs are cleared and the TAKE LED lights.

¹ You can press the OFF button first, and then the ALL button (the order is irrelevant)

7.2.5 Storing and Recalling Setups

You can store up to 60 settings in the non-volatile memory with the ability to recall each of those settings. Whenever a setup is stored (and in whatever mode), the following information is saved as an integral part of that stored setup:

- Video status
- Audio status
- Mode (*AUDIO-FOLLOW-VIDEO* or *BREAKAWAY*)

7.2.5.1 Storing Setups

To store a setting, do the following:

1. Press the STO button.

The Displays show the messages:

Enter SETUP number	Store
use two digit # 01-60	# xy

Where xy are the OUT buttons.

2. Press two OUT buttons, using the OUTkeys # 1 to 9, and 10 (for 0). The OUTkeys function on a decimal-basis, and not on a positional-basis. For example, to enter the # 14, press # 1 followed by # 4 (not # 14). To enter the # 3, press # 3 followed by the TAKE button¹.

The setups shown in the Displays blink. In addition, the TAKE LED and the appropriate mode button² also blink.

The Displays show the messages:

STORE this SETUP ?	Store
YES -> TAKE	# xy

3. Press the TAKE button.

The memory stores the setup and the MATRIX Display shows the message:

Setup # xy stored

Note, saving a setup to an already allocated setup #, prompts the message in the MATRIX Display:

Setup already exists
Press TAKE to overwrite

Pressing the TAKE button replaces the stored setup with the current setup. Alternatively, press a different OUT button to change the setup #.

¹ Alternatively, pressing # 10 followed by # 3 will also enter the # 3

² VIDEO, AUDIO or AFV

7.2.5.2 Recalling Setups

To recall a setting, do the following:

1. Press the *RCL* button.

The Displays show the messages:

Enter SETUP number RECALL
use two digit # 01-60 # xy

Where xy are the OUT buttons.

2. Press the appropriate two OUT buttons, using the OUTkeys # 1 to 9, and 10 (for 0). The OUTkeys function on a decimal-basis, and not on a positional-basis. For example, to enter the # 14, press # 1 followed by # 4 (not # 14). To enter the # 3, press # 3 followed by the TAKE button¹. The memory recalls the setup. The MATRIX Display shows the blinking setup, and the TAKE LED as well as the appropriate mode button² blinks. The STATUS Display shows the message:

RECALL
xy

Where xy are the OUT buttons.

3. Preview the setup to decide if to implement it, by pressing the:
 - VIDEO or the AUDIO button, for video or audio setups in the *BREAKAWAY* mode. Pressing the AFV button will have no effect if setups are stored in the *BREAKAWAY* mode
 - AFV button, for setups in the *AUDIO-FOLLOW-VIDEO* mode. Pressing the VIDEO or the AUDIO button will have no effect if setups are stored in the *AUDIO-FOLLOW-VIDEO* mode

If you decide not to implement the setup, you can scan the other setups, by pressing different OUT buttons. To stop previewing the setups, press a non-relevant button, for example, an IN button.

4. Press the TAKE button.
The specific setup is implemented.

If trying to recall an empty setup³, the MATRIX Display would show a message saying that that particular setup is empty and would return you to step 1 above.

1 Alternatively, pressing # 10 followed by # 3 will also enter the # 3

2 VIDEO, AUDIO or AFV

3 That is, a setup # for which no setup is actually stored

8 MENU Commands Sequence

You can press the MENU button up to 11 times in straight sequence to scan the range of commands.

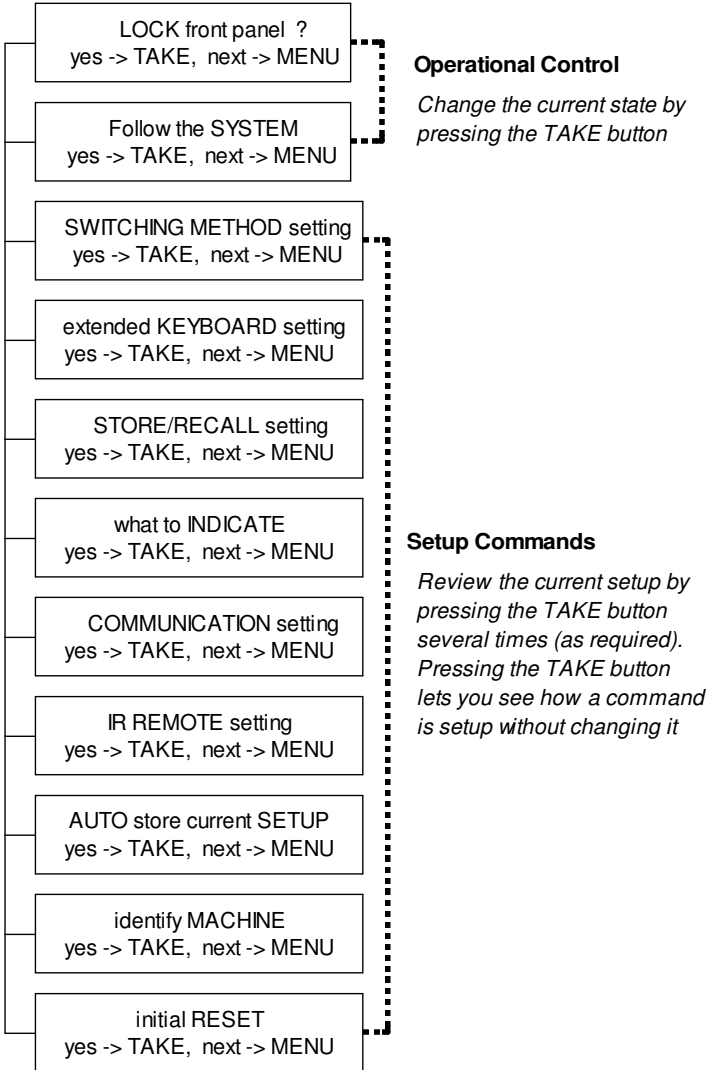

Figure 16: Sequence of MENU Commands

You can stop changing a setup at any time by pressing any IN button.

8.1 Locking and Unlocking the Front Panel

To prevent changing the settings accidentally or tampering with the unit via the front panel buttons, lock¹ your unit. Unlocking releases the protection mechanism.

To lock the unit:

1. Press the MENU button once.
The MATRIX Display shows the message:

LOCK front panel ?
yes -> TAKE, next -> MENU

2. Press the TAKE button.
The front panel locks and the Displays momentarily show the messages:

Front panel LOCKED Keyboard LOCKED³
to unlock- press MENU²

Pressing a front panel button has no effect⁴ but remote RS-232 and RS-485 commands function and show on the MATRIX Display.

To unlock the **VS-162AV**:

Either:

1. Press the MENU button.
The MATRIX Display shows the message:

to UNLOCK front panel
press TAKE

The TAKE LED blinks.

2. Press the TAKE button.
The front panel unlocks⁵ and the MATRIX Display momentarily² shows the message:

Front panel
UNLOCKED

Or:

1 Nevertheless, even though the front panel is locked you can still operate via RS-232 or RS-485 serial (remote controller or PC)

2 After a few seconds, the status of the unit replaces this message

3 This message appears continuously in the STATUS Display, until the front panel is unlocked

4 IR and Keyboard Extension (EXT. KEYS) commands are also blocked

5 Switching the power off and on again also unlocks the front panel

1. Press the *TAKE* button twice.
The front panel unlocks and the same messages show as in steps 1 and 2 above.

8.2 Choosing the Follow-System or Breakaway-From-System Mode

The terms *audio-follow-video*¹ and *audio breakaway*² are well known. Sometimes signals other than audio signals need to switch simultaneously and at other times, need to switch independently. For example:

- Non-linear editing systems, that sometimes combine video with analog audio and at other times combine video with digital audio
- Duplication systems, that make Master tapes from programs with different formats: composite analog, component analog and component digital

When the Follow-SYSTEM command is selected, the unit will automatically switch in the AUDIO-FOLLOW-VIDEO (AFV) mode and the AFV button illuminates.

When the BREAKAWAY from video command is selected (the Video or the Audio button illuminates), the unit automatically switches in the Breakaway-From-SYSTEM mode.

When the unit functions in the:

- *Follow-SYSTEM* mode, the unit switches with other 16x16 matrix switchers³, implementing the same action simultaneously
- *Breakaway-from-SYSTEM* mode, the unit⁴ functions independently, implementing an action independently of the others

The unit will function⁵ in the *Follow-SYSTEM* mode if at least one other unit⁶ is set to the *Follow-SYSTEM* mode and these units interconnect via an RS-232 and/or RS-485 communication line.

1 Video and the audio channels switch simultaneously in the same way

2 Audio channels switch independently from the video channels

3 16x16 matrix switchers in the same series, that include, for example, the VS-1616SDI (a 16x16 digital video matrix switcher), the VS-1616AD (a 16x16 digital audio matrix switcher), the VS-1616V (a 16x16 analog video matrix switcher), the VS-1616A (a 16x16 analog balanced stereo audio matrix switcher) units and/or the VS-162V (a 16x16 video matrix switcher)

4 Also applies to a VS-1616A unit or a VS-1616AD unit

5 The unit changes its status immediately and goes to the Follow-system mode

6 Or VS-1616A or VS-1616AD unit (as well as other 16x16 matrix switchers in the same series)

To set the unit to function in the *Follow-SYSTEM* mode:

1. Press the MENU button twice.
The MATRIX Display shows the message:

Follow the SYSTEM
yes -> TAKE, next -> MENU

2. Press the *TAKE* button.
The Displays show the messages:

set UNIT follow SYSTEM? current:
Press TAKE to execute breakaway

3. Press the *TAKE* button again.
The MATRIX Display momentarily shows this message, followed by the status of the switcher and in the STATUS Display the letter “S” is displayed behind the blinking cursor:

the UNIT is set in mode
FOLLOW system

If the status of the unit differs from that of the other unit(s), set the unit to the *Follow-SYSTEM* mode. The MATRIX Display blinks the new status of the switcher and the TAKE LED blinks. Pressing the *TAKE* button¹ implements all the changes to the same state as the rest of the system placing the switcher in the *Follow-SYSTEM* mode.

To set the unit to function in the *Breakaway-from-SYSTEM* mode:

1. Press the MENU button twice.
The MATRIX Display shows the message:

FOLLOW the system
yes -> TAKE, next -> MENU

2. Press the *TAKE* button.
The Displays show the messages:

BREAKAWAY from system? current:
Press TAKE to execute follow SYS

3. Press the *TAKE* button again.
The MATRIX Display shows the message:

the UNIT is set in mode
BREAKAWAY from system

¹ Pressing a different button cancels the operation and the switcher will remain in its previous state

8.3 Choosing the SWITCHING METHOD Setting

Section 8.3.1 describes the SWITCHING METHOD settings for stand alone units and large matrices. Section 8.3.2 describes how to configure a SWITCHING METHOD.

8.3.1 Understanding the SWITCHING METHOD Settings

Setting the unit as a Stand-Alone UNIT provides a choice of 3 SWITCHING METHOD settings:

- **NoVIS** - switching occurs immediately after completion of front panel or dry-contact operation or immediately after receiving an RS-232 or RS-485 command, or an IR command. The switching is independent of the vertical reference
- **EXT** (external sync) - switching occurs during the vertical interval of the video reference signal connected to the IN SYNC¹ connector (this signal should be properly terminated via the TERM button²)
- **INT# 1** (internal sync) - switching occurs during the vertical interval of the video reference signal connected to IN # 1

Setting the unit as a Large Matrix (instead of as a Stand-Alone UNIT) provides a choice of 4 SWITCHING METHOD settings:

- **NoVIS, EXT** or **INT# 1** (as described above)
- **MTX** (SYNC from Matrix) - the vertical interval of the video reference (selected on one unit in the Large Matrix system) is present on the “SYNC” RS-485 terminal block connector³. This reference signal applies to all switchers in the multi-switcher system and facilitates switching all **VS-162/VS-1616** series units simultaneously

To choose the MTX (SYNC from Matrix) setting⁴ as the example in Figure 17 illustrates:

- Connect the RS-485 terminal block connectors⁵ between each switcher in the multi-switcher system
- Connect and set the video reference signal on one of the video units to EXT (external sync) or INT# 1 (internal sync)
- Set the video reference on the other video units to the MTX (SYNC from Matrix) setting

1 Item 1 in Figure 2

2 Item 3 in Figure 2

3 Item 5 in Figure 2

4 This sets the matrix sync configuration from another (Master) machine

5 Via a straight connection of all 4 PINS

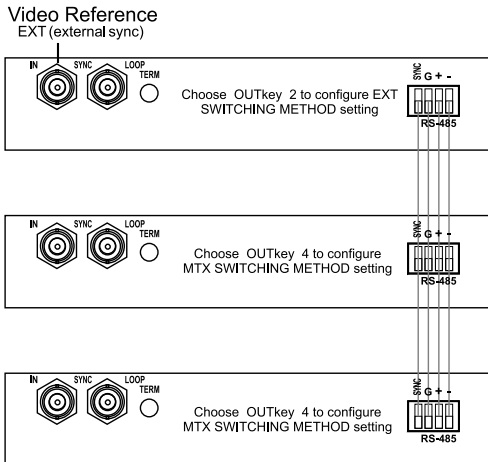

Figure 17: Choosing the MTX (SYNC from Matrix) Setting

8.3.2 Configuring a SWITCHING METHOD

To choose a SWITCHING METHOD setting, do the following:

1. Press the MENU button until you reach the SWITCHING METHOD setting. The MATRIX Display shows the message:

SWITCHING METHOD setting
yes -> TAKE, next -> MENU

2. Press the TAKE button. The Displays show the messages:

Use OUTkey to configure **Current**
1: noVIS 2: EXT 3: INT#1 4:MTX **External¹**

3. Press an OUT button from 1, 2, 3 or 4. For example, OUT button # 3 to set the internal sync configuration. The TAKE LED blinks and the MATRIX Display shows the message:

Press TAKE to configure
from INTERNAL (Input #1)

4. Press the TAKE button. The Displays show the messages:

SWITCHING METHOD **current:**
changed **From In #1**

¹ Indicating that the machine is currently set to the external switching method setting

STORE/RECALL setting
yes -> TAKE, next -> MENU

2. Press the *TAKE* button and choose the appropriate Outkey 1 for the AT ONCE mode (Outkey 2 is for the CONFIRM mode).
 The Displays show the messages:

STO/RCL mode
changed

current:
At once

8.6 Choosing what to INDICATE

Choose what is displayed during regular operation: between scrolling the switcher setup as Figure 18 illustrates, and showing the AUDIO mode.

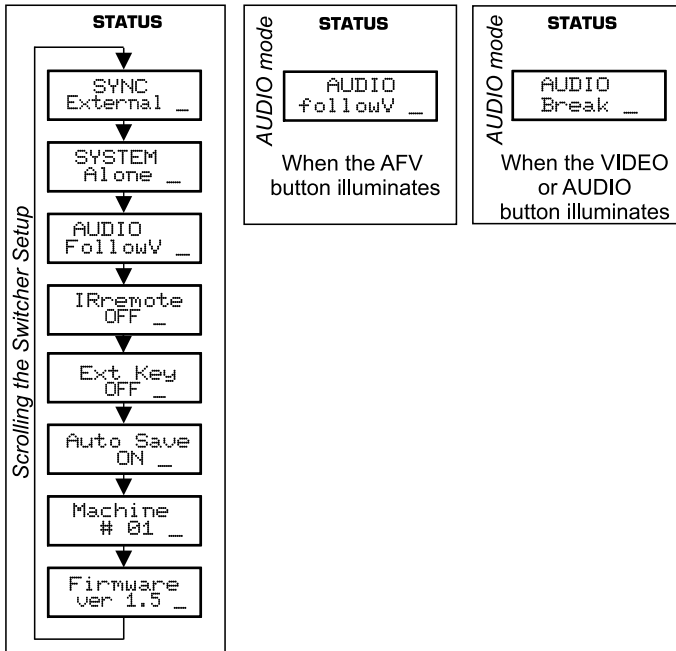

Figure 18: Choosing what to INDICATE

To scroll the switcher setup (instead of showing the AUDIO mode), do the following:

1. Press the MENU button until you reach the “What to INDICATE” command.
 The MATRIX Display shows the message:

what to INDICATE
yes -> TAKE, next -> MENU

2. Press the *TAKE* button.

The Displays show the messages:

Use OUTkey to configure **Current:**
1: scroll SETUP 2: AUDIO mode **AUDIO**

3. Press the *OUT* button 1.

The TAKE LED blinks and the Displays show the messages:

Scroll switcher setup? **Current:**
Press TAKE to execute **AUDIO**

4. Press the *TAKE* button.

The Displays show the messages:

display mode **Current:**
changed **SETUP**

8.7 Choosing the COMMUNICATION Setting

Choose the response option (reply or no reply).

To choose the No Reply response option, for example, do the following:

1. Press the MENU button until you reach the COMMUNICATION setting.
 The MATRIX Display shows the message:

COMMUNICATION setting
yes -> TAKE, next -> MENU

2. Press the *TAKE* button.

The MATRIX Display shows the message:

Use OUTkey to configure
1: REPLY 2: No Reply

3. Press the *OUT* button 2.

The TAKE LED blinks and the Displays show the messages:

Set serial port NO reply **Current:**
Press TAKE to execute **Reply**

4. Press the *TAKE* button again.

The Displays show the messages:

SWITCHER RESPONSE **Current:**
changed **No reply**

8.8 Setting the IR REMOTE Control

Set the IR REMOTE control to enable remote control of the *16x16 Audio-Video Matrix Switcher*, using the *Kramer Infra-Red Remote Control Device*¹. Refer to the *Infra-Red Remote Control Device* user manual², for full details. Table 6 and Table 7 summarize the setup and operational commands.

Table 6: Summary of Basic IR-1 Setups

To execute this command:	Press the following keys in this sequence:
Allocate the unit to Group 12	SHIFT + GROUP + 12
Set the MACHINE #	UNIT + # key ³ (according to the unit dipswitch settings)

To enable IR REMOTE control (when set OFF), do the following:

1. Press the MENU button until reaching the IR REMOTE setting.
The MATRIX Display shows the message:

IR REMOTE setting
yes -> TAKE, next -> MENU

2. Press the TAKE button.
The Displays show the messages:

Outkey 1: InfraredREMOTE OFF **current:**
2: InfraredREMOTE ON **remote OFF**

3. Press the OUT button 2.
The TAKE LED blinks and the Displays show the messages:

Turn ON infrared REMOTE ? **Current:**
Press TAKE to execute **remote OFF**

4. Press the TAKE button again.
The Displays show the messages:

Infrared REMOTE mode **Current:**
changed **remote ON**

Table 7: Summary of Basic IR-1 Operations

To execute this command:	Press the following keys in this sequence:
Switch an Input to an Output	# key (for the output) + # key (for the input) ⁴
Store/Recall a setup	SHIFT + STO/RCL + # key (for the setup)

1 After enabling the IR REMOTE control command, remotely control the unit via the IR-1 remote control transmitter pointed at the remote receiver on the machine's front panel (item 1 in Figure 2)

2 You can download the user manual: RC-IR1, IR-1, IR-1-01, from the Internet at <http://www.kramerelectronics.com>

3 For example, press UNIT + # 1 if the unit is set as MACHINE # 1

4 For example, press # 6 followed by # 2 to switch input 2 to output 6

8.9 Choosing the AUTO STORE Current SETUP

Choose whether or not to save the current setup automatically, that is, whether to save the machine's status on power down, so that it returns to the same status after cycling power.

To save the current setup automatically (when set OFF), do the following:

1. Press the MENU button until you reach the AUTO Store Current SETUP command.

The MATRIX Display shows the message:

AUTO store current SETUP
yes -> TAKE, next -> MENU

2. Press the TAKE button.

The Displays show the messages:

OUTkey 1: no AutoSave	current:
2: AutoSave CURRENT setup	NO save

3. Press the OUT button 2.

The TAKE LED blinks and the Displays show the messages:

Auto store CURRENT setup ?	Current:
Press TAKE to execute	NO save

4. Press the TAKE button again.

The Displays show the messages:

AUTOSAVE mode	Current:
changed	AutoSave

8.10 Identifying the MACHINE

Display essential information (the product name and version number) to identify your machine, for example, for technical support purposes.

To identify your machine, do the following:

1. Press the MENU button until you reach the Identifying the MACHINE command.

The MATRIX Display shows the message:

identify MACHINE
yes -> TAKE, next -> MENU

2. Press the TAKE button.

The MATRIX Display (as Figure 19 illustrates) shows the message:

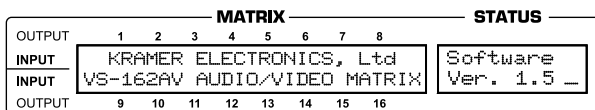

Figure 19: Machine Identification

8.11 Choosing the initial RESET

Choose to reset the machine¹ to the:

- Current status² (reloads the current setup)
- Factory default (resets to the pre-installed factory default state³)

Each **VS-162AV** unit ships in its factory default

To reset the machine, do the following:

1. Press the MENU button until you reach the initial RESET command.
The MATRIX Display shows the message:

initial RESET
yes -> TAKE, next -> MENU

2. Press the TAKE button.
The MATRIX Display shows the message:

Outkey 1: Current status
2: Factory default

3. Press the OUT button 2, for example, to reset to the factory default.
The TAKE LED blinks and the Displays show the messages:

Reset to factory default **WARNING**
Press TAKE to execute **!!!!**

4. Press the TAKE button again.
The Displays show the messages:

Reset to factory default **WARNING !!!!!**
confirm by pressing OUT # 7

5. Press the OUT # 7.
The machine resets to the factory default and the Displays show the first messages of the reloading progress (as Figure 19 illustrates).

¹ Without having to switch the power off and on

² Sometimes called a “soft reset”

³ Each unit ships in its factory default state that is a 16x16 audio-video matrix, with all setups empty and each input connected to its corresponding output (for example, 1-to-1)

9 Flash Memory Upgrade

The main part of the unit firmware is located in FLASH¹ memory, which lets you upgrade to the latest Kramer firmware version in minutes!

Download the up-to-date file from the Internet or obtain it from your dealer. The following example shows how to install a file named (for example) “162-15.hex” to the FLASH memory².

The current unit software version shows in the *STATUS* display as Figure 15 illustrates in section 7.1.

9.1 Connecting the PC to the RS-232 Port

Before installing the latest Kramer firmware version on a unit, connect:

- The COM port on your PC to the RS-232 IN port on the unit

When simultaneously upgrading the firmware on several units:

- Connect the COM port on your PC to the RS-232 IN port on the first unit
- Connect the RS-232 OUT port on the first unit to the RS-232 IN port on the second unit or another 16x16 unit
- Connect all 16x16 units that you want to upgrade, in this way, linking them in a daisy chain connection
- Set DIP 7 according to whether or not a Null-modem connection is being used³

9.2 Upgrading Firmware

1. Install and run the *K-Sender* program on your PC.
2. Open the *K-Sender* program.
The File COM Port Sender window opens.
3. Choose the appropriate COM port.
Be sure that “9600 Baudrate” is chosen.
Click the *File* button.
4. Locate the file “162-15.hex” and click the *Open* button.
The filename appears in the lower part of the window (in bold script).

¹ Electrically programmable and erasable

² The number “15” in the file name indicates the version number “1.5”. Be sure you receive the latest version, and that it is a “.hex” file

³ Refer to section 6.3 for full details

5. Press and **hold** the *TAKE* button while simultaneously turning on the *POWER* switch on the unit.
After a few seconds, following the initial machine identification message, the MATRIX Display shows the following message:

**Please,
release key TAKE**

6. Release the *TAKE* button.
The TAKE LED blinks and the MATRIX Display shows the following message:

**Update program?
Please confirm < TAKE >**

7. Press the *TAKE* button.
The MATRIX Display shows the following message:

**YOU will lose current SETUP¹
Confirm < TAKE >**

8. Press the *TAKE* button again.
The MATRIX Display shows the following message:

**Are you ABSOLUTELY sure?
Press TAKE to execute**

At this stage, and at any time previously, you can cancel the operation by pressing any button, other than the TAKE button.

9. Press the *TAKE* button once again.
The program starts working and the TAKE LED turns off.
The MATRIX Display shows the following message:

**ERASE flash MEMORY
Please, wait...**

10. After a few seconds the FLASH memory is erased and the MATRIX Display shows the following message:

**Ready for receiving
Start transmission from PC**

Note: If upgrading the firmware on more than one unit, be sure to perform the above steps, 5 to 9, on each unit before continuing.

¹ Upgrading firmware resets your unit to the factory default. This includes erasing all setups

10 Technical Specifications

Table 8 includes the technical specifications:

Table 8: Technical Specifications¹ of VS-162AV / VS-162AVRCA

INPUTS:	VIDEO: 16 composite video 1 Vpp / 75Ω on BNC connectors AUDIO: 16 balanced audio 10kΩ on detachable terminal block connectors (VS-162AV) / 16 unbalanced audio on RCA connectors (VS-162AVRCA)	
OUTPUTS:	VIDEO: 16 composite video 1 Vpp / 75Ω on BNC connectors AUDIO: 16 balanced audio 50Ω on detachable terminal block connectors (VS-162AV) / 16 unbalanced audio on RCA connectors (VS-162AVRCA)	
MAX. OUTPUT LEVEL:	VIDEO: 2.2 Vpp	AUDIO: 20dBm
BANDWIDTH (-3dB):	VIDEO: 90 MHz -3dB	AUDIO: >100 kHz
DIFF. GAIN:	<0.18%	
DIFF. PHASE:	± 0.4 Deg.	
K-FACTOR:	<0.05%	
S/N RATIO:	VIDEO: 76.1dB	AUDIO: 82.2dB, unweighted, RL = 10kΩ
CROSSTALK (all hostile):	VIDEO: <-46dB @ 5MHz	AUDIO: -80dB @ 1kHz
CONTROLS:	41 selector switches; RS-232, RS-485, IR remote, dry keyboard extension	
COUPLING:	VIDEO: DC	AUDIO: AC
AUDIO THD + NOISE:	0.04% @ 1kHz	
AUDIO 2 nd HARMONIC:	0.002%	
POWER SOURCE:	230 VAC, 50/60 Hz, (115VAC, U.S.A.) 14VA	
DIMENSIONS:	19-inch (W), 7-inch (D) 2U (H) rack-mountable	
WEIGHT:	3.7 kg (8.2 lbs.) approx	
ACCESSORIES:	Power cord, Null modem adapter, Windows®-based Kramer control software	

11 Communication Protocol

Table 9 includes the Protocol 2000² hexadecimal codes³. The communication parameters are: 9600 baud, with no parity, 8 data bits and 1 stop bit.

1 Specifications are subject to change without notice

2 Full details are available on our Web site: www.kramerelectronics.com

3 This example assumes MACHINE # 1, and node 0

Table 9: Hex Table for the VS-162AV / VS-162AVRCA Audio-Video Matrix Switcher

	OUT 1	OUT 2	OUT 3	OUT 4	OUT 5	OUT 6	OUT 7	OUT 8	OUT 9	OUT 10	OUT 11	OUT 12	OUT 13	OUT 14	OUT 15	OUT 16	
IN 1	01 81 81 81	01 81 82 81	01 81 83 81	01 81 84 81	01 81 85 81	01 81 86 81	01 81 87 81	01 81 88 81	01 81 89 81	01 81 8A 81	01 81 8B 81	01 81 8C 81	01 81 8D 81	01 81 8E 81	01 81 8F 81	01 81 90 81	01 81 90 81
IN 2	01 82 81 81	01 82 82 81	01 82 83 81	01 82 84 81	01 82 85 81	01 82 86 81	01 82 87 81	01 82 88 81	01 82 89 81	01 82 8A 81	01 82 8B 81	01 82 8C 81	01 82 8D 81	01 82 8E 81	01 82 8F 81	01 82 90 81	01 82 90 81
IN 3	01 83 81 81	01 83 82 81	01 83 83 81	01 83 84 81	01 83 85 81	01 83 86 81	01 83 87 81	01 83 88 81	01 83 89 81	01 83 8A 81	01 83 8B 81	01 83 8C 81	01 83 8D 81	01 83 8E 81	01 83 8F 81	01 83 90 81	01 83 90 81
IN 4	01 84 81 81	01 84 82 81	01 84 83 81	01 84 84 81	01 84 85 81	01 84 86 81	01 84 87 81	01 84 88 81	01 84 89 81	01 84 8A 81	01 84 8B 81	01 84 8C 81	01 84 8D 81	01 84 8E 81	01 84 8F 81	01 84 90 81	01 84 90 81
IN 5	01 85 81 81	01 85 82 81	01 85 83 81	01 85 84 81	01 85 85 81	01 85 86 81	01 85 87 81	01 85 88 81	01 85 89 81	01 85 8A 81	01 85 8B 81	01 85 8C 81	01 85 8D 81	01 85 8E 81	01 85 8F 81	01 85 90 81	01 85 90 81
IN 6	01 86 81 81	01 86 82 81	01 86 83 81	01 86 84 81	01 86 85 81	01 86 86 81	01 86 87 81	01 86 88 81	01 86 89 81	01 86 8A 81	01 86 8B 81	01 86 8C 81	01 86 8D 81	01 86 8E 81	01 86 8F 81	01 86 90 81	01 86 90 81
IN 7	01 87 81 81	01 87 82 81	01 87 83 81	01 87 84 81	01 87 85 81	01 87 86 81	01 87 87 81	01 87 88 81	01 87 89 81	01 87 8A 81	01 87 8B 81	01 87 8C 81	01 87 8D 81	01 87 8E 81	01 87 8F 81	01 87 90 81	01 87 90 81
IN 8	01 88 81 81	01 88 82 81	01 88 83 81	01 88 84 81	01 88 85 81	01 88 86 81	01 88 87 81	01 88 88 81	01 88 89 81	01 88 8A 81	01 88 8B 81	01 88 8C 81	01 88 8D 81	01 88 8E 81	01 88 8F 81	01 88 90 81	01 88 90 81
IN 9	01 89 81 81	01 89 82 81	01 89 83 81	01 89 84 81	01 89 85 81	01 89 86 81	01 89 87 81	01 89 88 81	01 89 89 81	01 89 8A 81	01 89 8B 81	01 89 8C 81	01 89 8D 81	01 89 8E 81	01 89 8F 81	01 89 90 81	01 89 90 81
IN 10	01 8A 81 81	01 8A 82 81	01 8A 83 81	01 8A 84 81	01 8A 85 81	01 8A 86 81	01 8A 87 81	01 8A 88 81	01 8A 89 81	01 8A 8A 81	01 8A 8B 81	01 8A 8C 81	01 8A 8D 81	01 8A 8E 81	01 8A 8F 81	01 8A 90 81	01 8A 90 81
IN 11	01 8B 81 81	01 8B 82 81	01 8B 83 81	01 8B 84 81	01 8B 85 81	01 8B 86 81	01 8B 87 81	01 8B 88 81	01 8B 89 81	01 8B 8A 81	01 8B 8B 81	01 8B 8C 81	01 8B 8D 81	01 8B 8E 81	01 8B 8F 81	01 8B 90 81	01 8B 90 81
IN 12	01 8C 81 81	01 8C 82 81	01 8C 83 81	01 8C 84 81	01 8C 85 81	01 8C 86 81	01 8C 87 81	01 8C 88 81	01 8C 89 81	01 8C 8A 81	01 8C 8B 81	01 8C 8C 81	01 8C 8D 81	01 8C 8E 81	01 8C 8F 81	01 8C 90 81	01 8C 90 81
IN 13	01 8D 81 81	01 8D 82 81	01 8D 83 81	01 8D 84 81	01 8D 85 81	01 8D 86 81	01 8D 87 81	01 8D 88 81	01 8D 89 81	01 8D 8A 81	01 8D 8B 81	01 8D 8C 81	01 8D 8D 81	01 8D 8E 81	01 8D 8F 81	01 8D 90 81	01 8D 90 81
IN 14	01 8E 81 81	01 8E 82 81	01 8E 83 81	01 8E 84 81	01 8E 85 81	01 8E 86 81	01 8E 87 81	01 8E 88 81	01 8E 89 81	01 8E 8A 81	01 8E 8B 81	01 8E 8C 81	01 8E 8D 81	01 8E 8E 81	01 8E 8F 81	01 8E 90 81	01 8E 90 81
IN 15	01 8F 81 81	01 8F 82 81	01 8F 83 81	01 8F 84 81	01 8F 85 81	01 8F 86 81	01 8F 87 81	01 8F 88 81	01 8F 89 81	01 8F 8A 81	01 8F 8B 81	01 8F 8C 81	01 8F 8D 81	01 8F 8E 81	01 8F 8F 81	01 8F 90 81	01 8F 90 81
IN 16	01 90 81 81	01 90 82 81	01 90 83 81	01 90 84 81	01 90 85 81	01 90 86 81	01 90 87 81	01 90 88 81	01 90 89 81	01 90 8A 81	01 90 8B 81	01 90 8C 81	01 90 8D 81	01 90 8E 81	01 90 8F 81	01 90 90 81	01 90 90 81

LIMITED WARRANTY

Kramer Electronics (hereafter *Kramer*) warrants this product free from defects in material and workmanship under the following terms.

HOW LONG IS THE WARRANTY

Labor and parts are warranted for three years from the date of the first customer purchase.

WHO IS PROTECTED?

Only the first purchase customer may enforce this warranty.

WHAT IS COVERED AND WHAT IS NOT COVERED

Except as below, this warranty covers all defects in material or workmanship in this product. The following are not covered by the warranty:

1. Any product which is not distributed by Kramer, or which is not purchased from an authorized Kramer dealer. If you are uncertain as to whether a dealer is authorized, please contact Kramer at one of the agents listed in the web site www.kramerelectronics.com.
2. Any product, on which the serial number has been defaced, modified or removed.
3. Damage, deterioration or malfunction resulting from:
 - i) Accident, misuse, abuse, neglect, fire, water, lightning or other acts of nature
 - ii) Product modification, or failure to follow instructions supplied with the product
 - iii) Repair or attempted repair by anyone not authorized by Kramer
 - iv) Any shipment of the product (claims must be presented to the carrier)
 - v) Removal or installation of the product
 - vi) Any other cause, which does not relate to a product defect
 - vii) Cartons, equipment enclosures, cables or accessories used in conjunction with the product

WHAT WE WILL PAY FOR AND WHAT WE WILL NOT PAY FOR

We will pay labor and material expenses for covered items. We will not pay for the following:

1. Removal or installations charges.
2. Costs of initial technical adjustments (set-up), including adjustment of user controls or programming. These costs are the responsibility of the Kramer dealer from whom the product was purchased.
3. Shipping charges.

HOW YOU CAN GET WARRANTY SERVICE

1. To obtain service on you product, you must take or ship it prepaid to any authorized Kramer service center.
2. Whenever warranty service is required, the original dated invoice (or a copy) must be presented as proof of warranty coverage, and should be included in any shipment of the product. Please also include in any mailing a contact name, company, address, and a description of the problem(s).
3. For the name of the nearest Kramer authorized service center, consult your authorized dealer.

LIMITATION OF IMPLIED WARRANTIES

All implied warranties, including warranties of merchantability and fitness for a particular purpose, are limited in duration to the length of this warranty.

EXCLUSION OF DAMAGES

The liability of Kramer for any effective products is limited to the repair or replacement of the product at our option. Kramer shall not be liable for:

1. Damage to other property caused by defects in this product, damages based upon inconvenience, loss of use of the product, loss of time, commercial loss; or
2. Any other damages, whether incidental, consequential or otherwise. Some countries may not allow limitations on how long an implied warranty lasts and/or do not allow the exclusion or limitation of incidental or consequential damages, so the above limitations and exclusions may not apply to you.

This warranty gives you specific legal rights, and you may also have other rights, which vary from place to place.

NOTE: All products returned to Kramer for service must have prior approval. This may be obtained from your dealer.

This equipment has been tested to determine compliance with the requirements of:

EN-50081:	"Electromagnetic compatibility (EMC); generic emission standard. Part 1: Residential, commercial and light industry"
EN-50082:	"Electromagnetic compatibility (EMC) generic immunity standard. Part 1: Residential, commercial and light industry environment".
CFR-47:	FCC Rules and Regulations: Part 15: "Radio frequency devices Subpart B – Unintentional radiators"

CAUTION!

- ☒ Servicing the machines can only be done by an authorized Kramer technician. Any user who makes changes or modifications to the unit without the expressed approval of the manufacturer will void user authority to operate the equipment.
- ☒ Use the supplied DC power supply to feed power to the machine.
- ☒ Please use recommended interconnection cables to connect the machine to other components.



For the latest information on our products and a list of Kramer distributors, visit our Web site: www.kramerelectronics.com, where updates to this user manual may be found. We welcome your questions, comments and feedback.



Caution

Safety Warning:

Disconnect the unit from the power supply before opening/servicing.



P/N: 2900-000071



Rev: 1

Kramer Electronics, Ltd.

Web site: www.kramerelectronics.com

E-mail: info@kramerelectronics.com

P/N: 2900-000071 REV 1