

## Component List

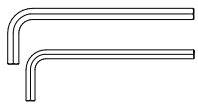

Large Hex Wrench x 1

Small Hex Wrench x 1

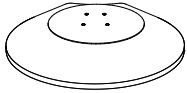

A - Base x 1



B - Adjustable Glides x 5



D - Spine x 1

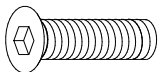

E - 3/8 x 1.25" Flat Head Screw x 4

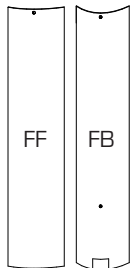

FF - Front Panel x 1

FB - Back Cover Panel x 1



G - 5/8" Long Phillips Head Screw x 3

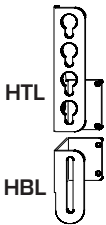

HTL

HBL



HTR

HBR

Screen Brackets x 4



I - 5/16 x .75" Pan Head Screw x 16



L - Washer x 4



M - Nut x 4

Your Vista<sup>®</sup> Home Theater Furniture is engineered for easy assembly. Carefully follow this procedure to prevent any damage.

## Placement and Maintenance

Vista<sup>®</sup> Home Theater Furniture is designed for indoor use on level floors. Clean glass with glass cleaner and steel parts with a moist cloth.

## Step 1

### Unpack and Identify

Unpack and identify the components. Note that some components are shipped inside the cabinet. The assembly workspace should be a non-marring surface such as carpet. For missing hardware pieces, please contact BDI Customer Service at customerservice@bdiusa.com. For all other concerns, please contact your BDI Retailer.

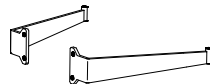

N - Shelf Brackets  
2 Left + 2 Right with 9960

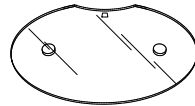

O - Glass Shelf  
x 2 with Model 9960

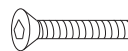

P - M8 x 1.5" Flat Head Screw  
x 4 with 9960

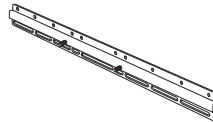

S - Horizontal Mounting Bars x 2



T - Small Spacers x 4



U - Large Spacers x 4

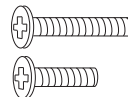

V - Phillips Head Mounting Screws  
(various thread sizes) x 32

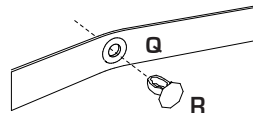

Q - Wire Management Strap x 3

R - Plastic Fastening Pin x 3

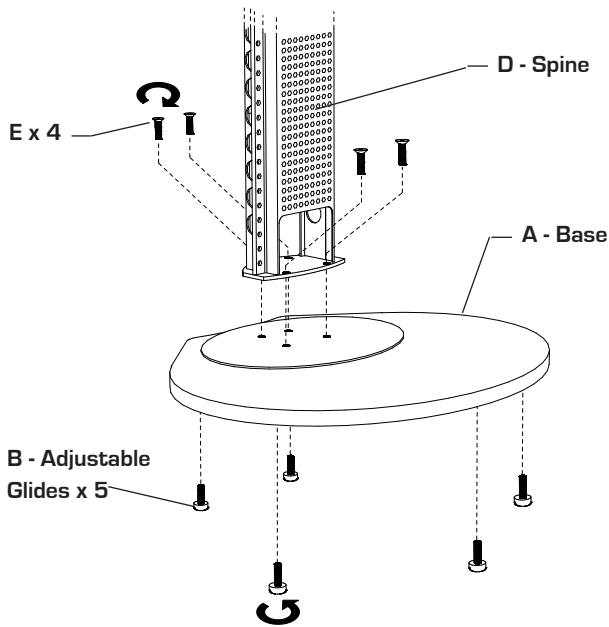

Figure 1

**Step 2**

**Attach Glides**

Thread **Adjustable Glides (B)** into holes on underside of **Base (A)** (Figure 1).

**Step 3**

**Attach Spine**

Attach **Spine (D)** to **Base (A)** using 4 - 3/8" x 1.25" **Flat Head Screws (E)** and **Large Hex Wrench** provided (Figure 1).

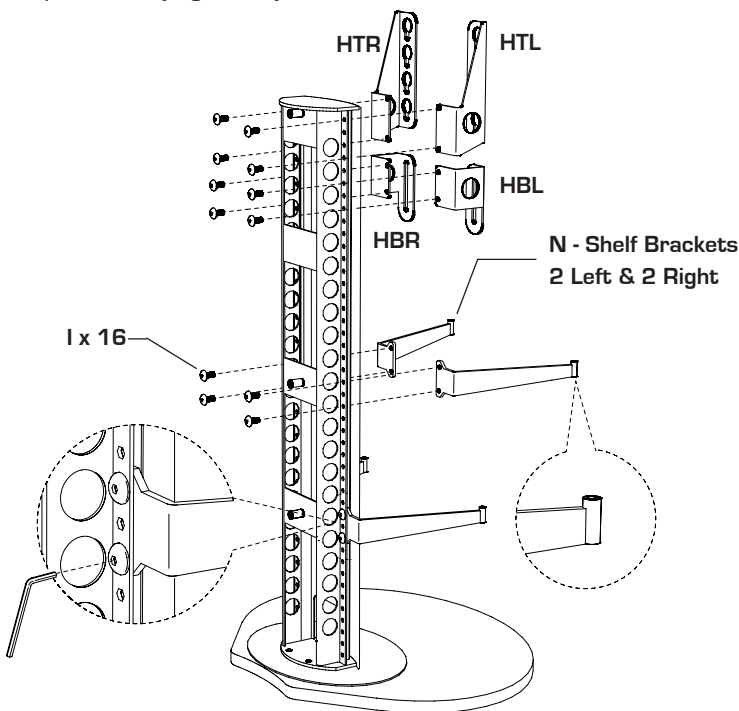

Figure 3

**Step 5**

**Attach Shelf & Screen Brackets**

Attach **Shelf (N)** & **Screen Brackets (HTR, HTL, HBR, HBL)** as shown with 3/4" **Pan Head Screws (I)** (Figure 3) using **Large Hex Wrench**. Slots on the face of the screen brackets should face forward. Screen brackets may need to be adjusted up or down to align with horizontal bars.

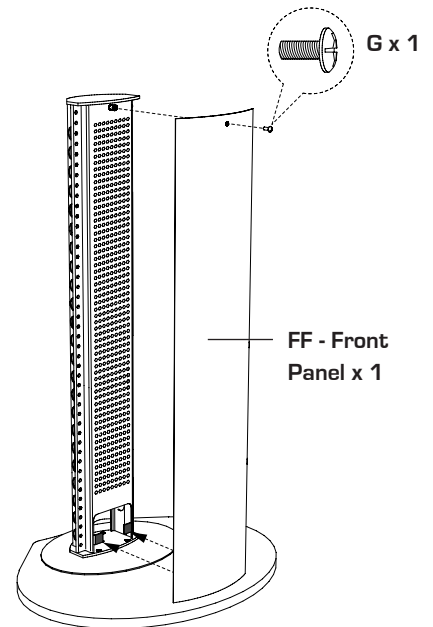

Figure 2

**Step 4**

**Attach Front Cover Panel**

Install **Front Cover Panel (F)** to front of spine using **5/8" Long Phillips Head Screw (G)** as shown (Figure 2). Bottom end of cover panel is attached with hook and loop pads. **Note:** The front cover panel has a flatter curve. Back panel has a notch at the bottom.

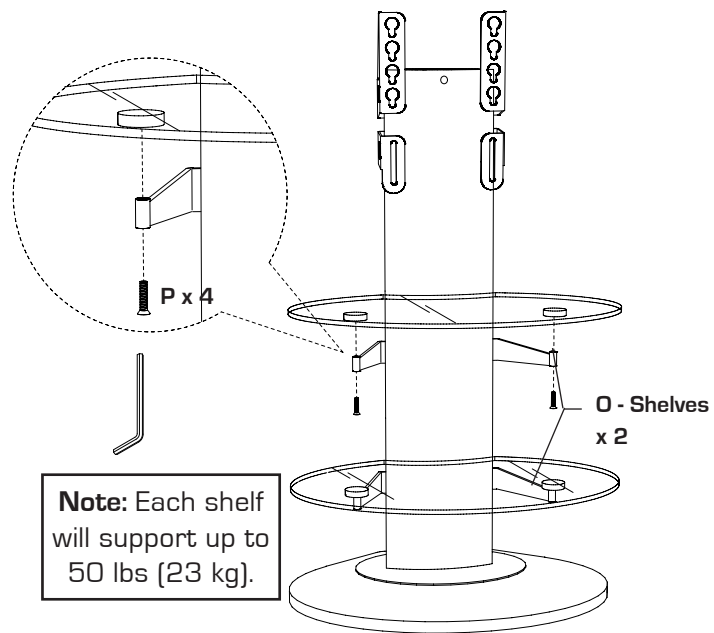

Figure 4

**Step 5**

**Install glass shelves.**

First, position **Glass Shelf (O)** so that discs are resting on the ends of the **Shelf Brackets (N)**. Keeping one hand on the shelf, pick up one **M8 x 1.5" Flat Head Socket Screw (P)** and thread up through the bottom of the cylinder into the hole on the bottom of the glass mounting disc. Thread second screw into second disc. Using **Small Hex Wrench**, fully tighten both left and right discs.

**Note:** Each shelf will support up to 50 lbs (23 kg).

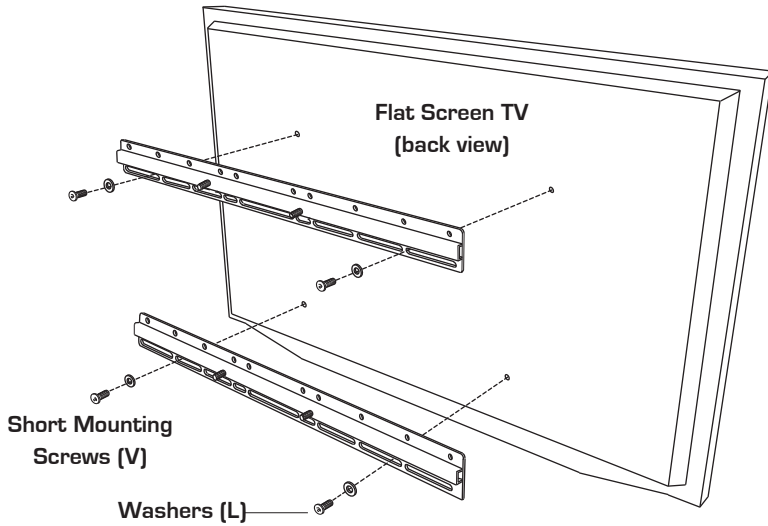

Figure 5

**Step 6**

**Install Horizontal Mounting Bars**

Find mounting screws that came with your flat screen TV. If screws are not available, find the **Short Phillips Head Mounting Screws (V)** provided with Vista that thread cleanly into the mounting holes in the back of your TV. The following thread sizes are included: **M5, M6, M8, 10-32 & 1/4-28**. Attach both **Horizontal Mounting Bar (S)** to TV as shown (Figure 5) using **Washers (L)** and Phillips driver. **Note:** If back of TV has a curved surface, or, if bars do not sit flat, use **Spacers (T or U)** and **Long Mounting Screws (V)** provided. Make sure bars are centered left to right! Button hooks should be on top and threaded studs on bottom. **Fully tighten bars to TV!**

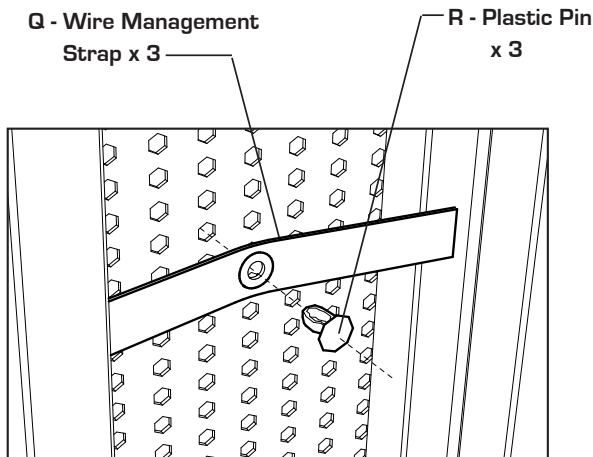

Figure 7

**Step 8**

**Install Wire Management Straps**

**Wire Management Straps (Q)** attach to the perforated metal panel inside the Vista spine simply by pushing the **Plastic Pin (R)** into the hole in the center of the strap and into one of the holes on the panel (Figure 7). Wrap straps around cords as shown (Figure 8). Straps may be relocated simply by pulling out and pushing plastic pin into another hole.

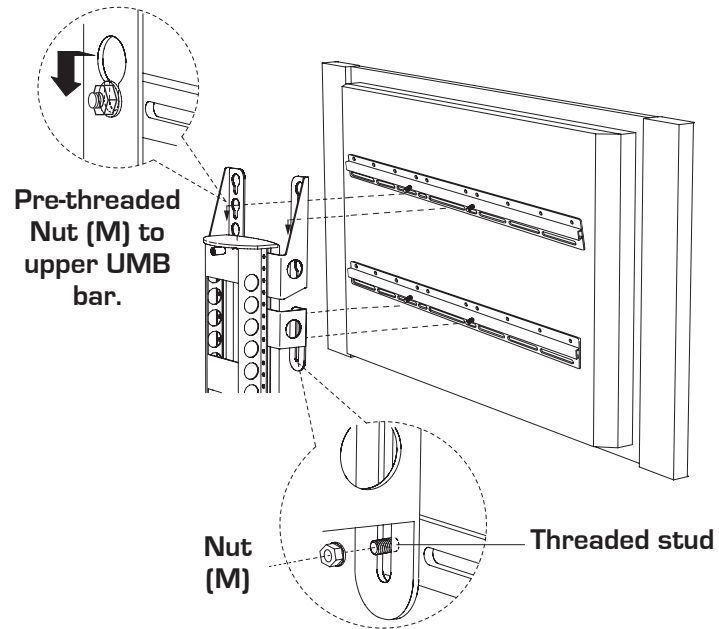

Figure 6

**Step 7**

**Attach flat screen TV**

Carefully “hook” TV onto screen brackets as shown (Figure 6). Make sure both pre-threaded nuts drop into key hole slot and that threaded studs go into slot on **Bottom Screen Brackets (HBL & HBR)**. Tighten **Nuts (M)** using wrench. **Note:** Vista will support flat screens up to 225lbs (102kg). **Note:** Vista is NOT designed to support televisions greater than 6” in depth.

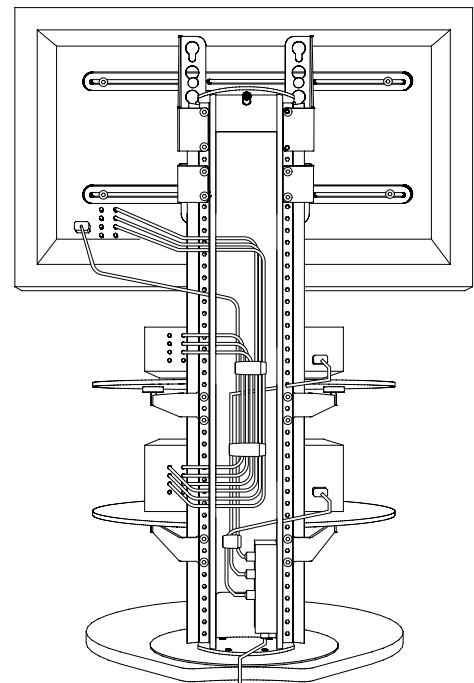

Figure 4

**Step 9**

**Install Back Cover Panel**

When all wires are in place and secured, install **Back Cover Panel (FB)** using 2 remaining **5/8” long Phillips Head Screws (G)**. Carefully, move Vista into place by pulling and lifting on lower shelf bracket elbows. Adjust glides if necessary.