

### Component List

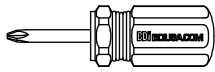

**A** - Phillips Screwdriver

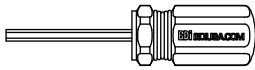

**B** - 4mm Hex Driver



**C** - Dowel Pin x 8



**D** - Cam Bolt x 4



**E** - Cam Fastener  
x 4

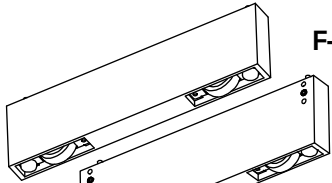

**F** - Leg Assembly  
x 2

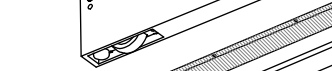

**G** - Rear Rail x 1

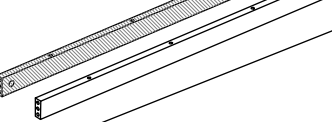

**H** - Front Rail x 1

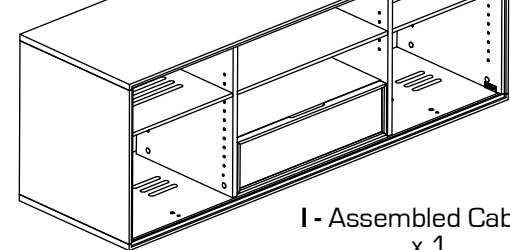

**I** - Assembled Cabinet  
x 1



**J** - Washer x 8



**K** - 1/4-20 x 55mm  
Machine Screw x 8



**L** - 1/4-20 x 90mm  
Machine Screw x 2



**M** - 1/4-20 x 38mm  
Machine Screw x 4

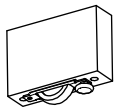

**N** - Center Wheel Block  
x 1

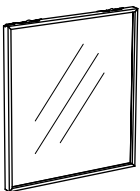

**O** - Sliding Door x 2

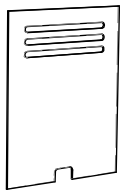

**P** - Back Panel  
x 2

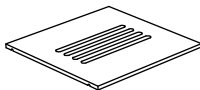

**R** - Adjustable Shelf  
x 4

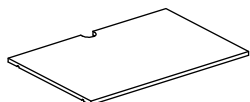

**Q** - Adjustable  
Center Shelf x 1

Cirrus is engineered for easy assembly. Carefully follow this procedure to prevent any damage.

### Placement and Maintenance

Cirrus is designed for indoor use on level floors. Clean glass with glass cleaner, and steel parts and wood veneer with a moist cloth.

### Step 1

#### Unpack and Identify

Unpack and identify the components at left. Note that some components are shipped inside the cabinet. The assembly workspace should be a nonmarring surface such as carpet. For missing hardware pieces, please contact BDI Customer Service at customerservice@bdiusa.com. For all other concerns, please contact your BDI Retailer.

### Step 2

#### Build Base Assembly

Install **Cam Bolts (D)** near front and rear edge of each **Leg Assembly (F)** using provided **Phillips Screwdriver (A)**. Next, insert **Dowel Pins (C)** into holes at ends of **Front Rail (H)** and **Rear Rail (G)**. Then join both Rails and Leg Assemblies together, aligning holes for all **Cam Bolts** and **Dowel Pins**.

Once all **Cam Bolts** and **Dowel Pins** are fully inserted to the respective holes, fasten together by inserting **Cam Fastener (E)** and turning about one-half turn clockwise using **Phillips Screwdriver (A)**.

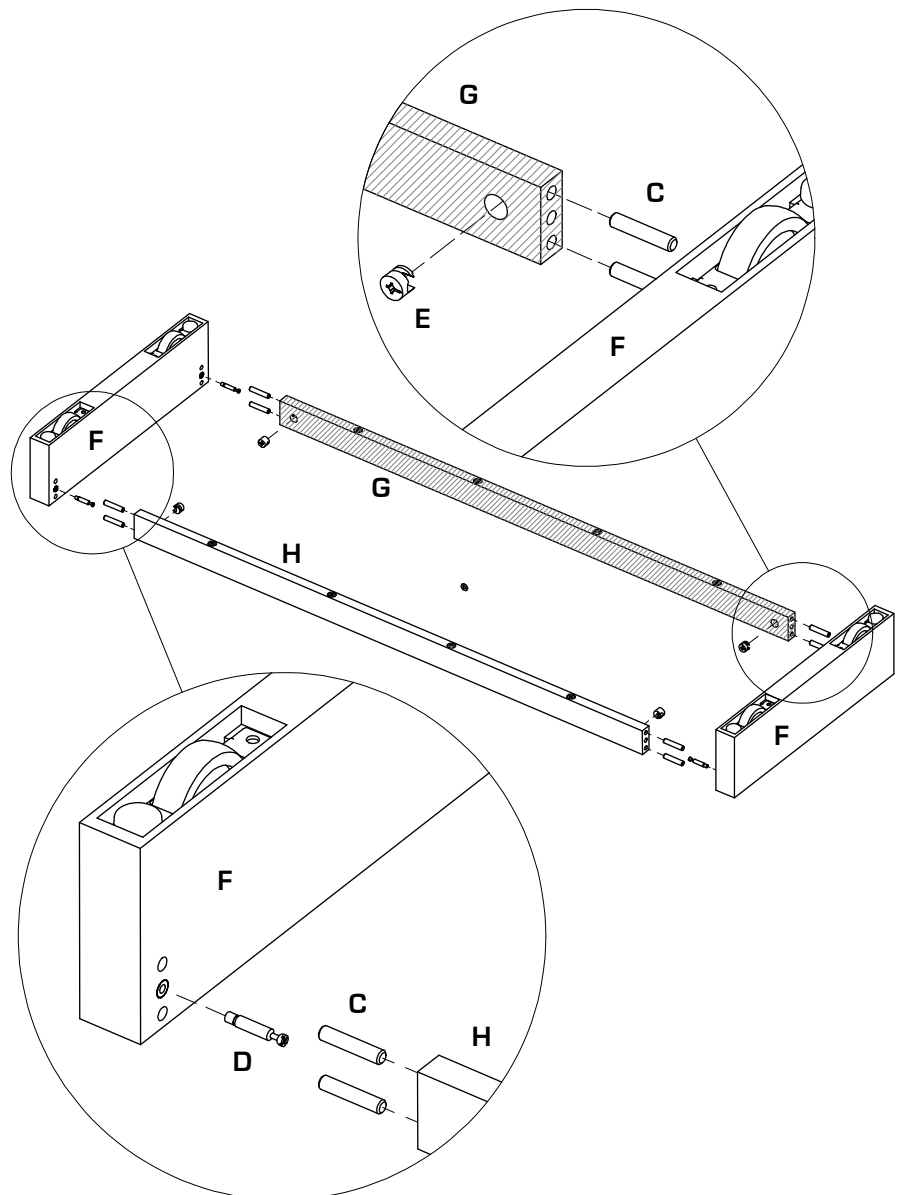

### Step 3

#### Attach Base Assembly

Attach Base Assembly to **Assembled Cabinet (I)** with **Front Rail (H)** oriented towards cabinet front (see drawing). Fasten into place using **Washers (J)** and **Screws (K)** at **Front Rail (H)** and **Rear Rail (G)** and tighten with **Hex Driver (B)**.

**Leg Assembly (F)**

**Rear Rail (G)**  
is painted Black

**Front Rail (H)**  
is wood veneered

**Leg Assembly (F)**

#### NOTE:

Levelers are present at the front and rear underside of each Leg Assembly. Each Leveler is manually adjustable by hand-turning to extend or retract to the desired position. Such adjustment will help offset uneven flooring and/or will prevent the cabinet from rolling.

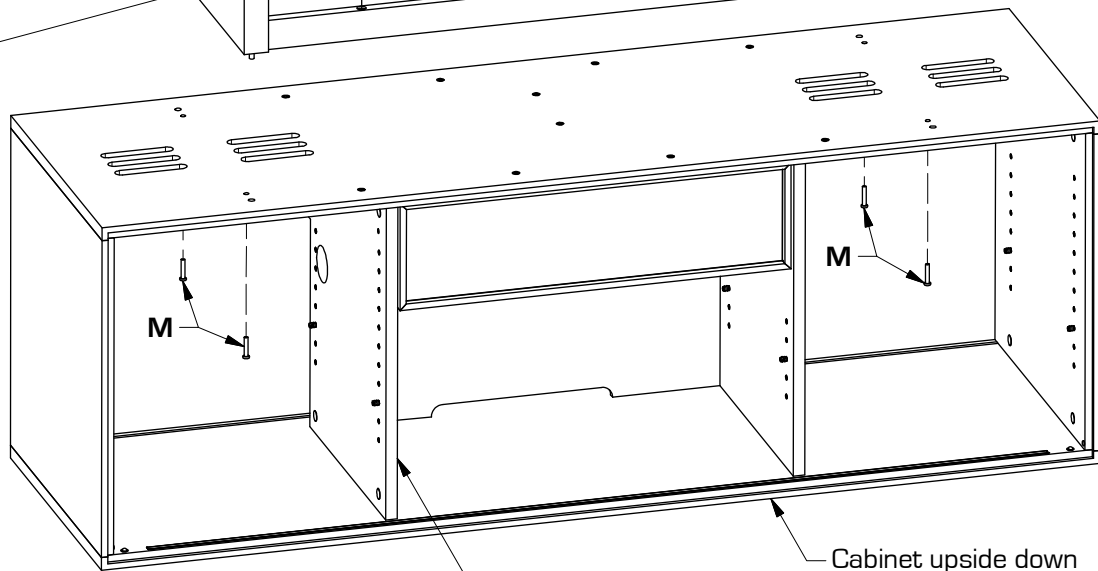

### Step 4

#### Install Screws into Leg Assembly

Install **Screws (M)** into **Leg Assembly (F)** and tighten with **Hex Driver (B)**.

**Assembled Cabinet (I)**  
Front

Cabinet upside down on carpeted floor to protect finish.

### Step 5

#### Attach Center Wheel Block

Attach **Center Wheel Block (N)** to cabinet's bottom panel using **Screws (L)** and tighten with **Hex Driver (B)**.

**Screws (L)**

**Center Wheel Block (N)**  
Leveler towards front

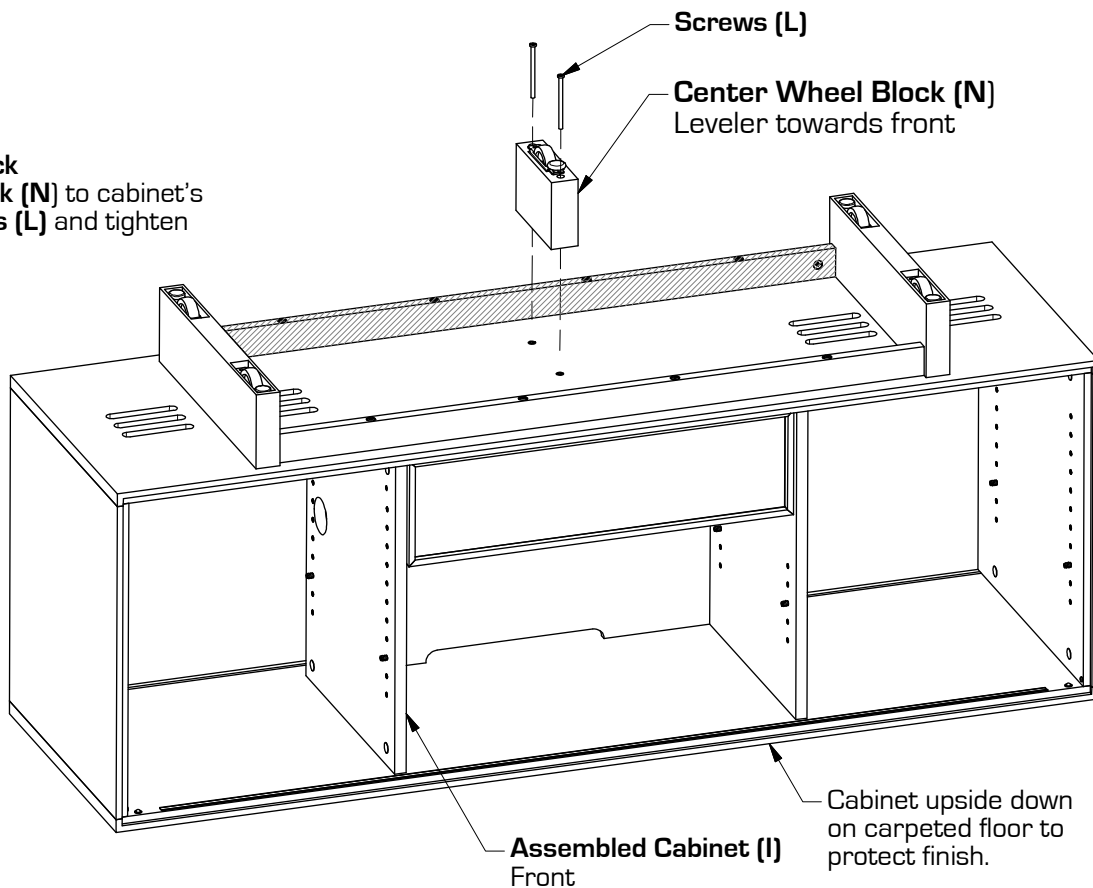

Cabinet upside down on carpeted floor to protect finish.

**Assembled Cabinet (I)**  
Front

## Step 6

### Install Sliding Doors

Install **Sliding Doors (O)** by carefully inserting wheels at door edge with brass plate into track as shown. Make sure each door rolls smoothly side to side, then push downward with gentle, firm motion and tip wheels at opposite door edge carefully into opposite track.

**NOTE: Match Labels on Door with Labels on Cabinet.**

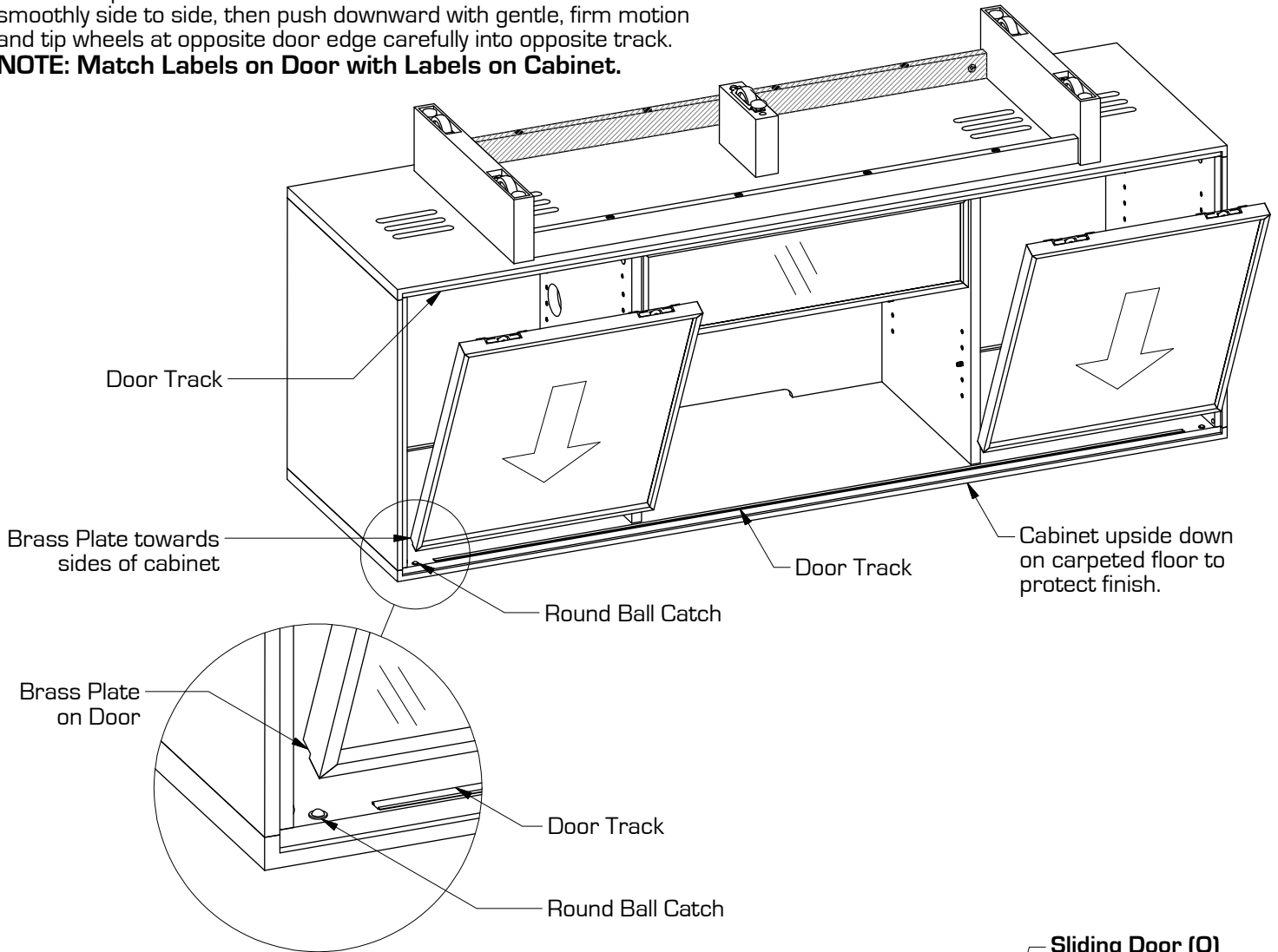

### Optional Step Adjust Height of Doors

In case door is not aligned properly, fixed wheel rollers on the bottom of each door are height-adjustable. Loosen two (2) inner screws using **Phillips Screwdriver (A)**, raise or lower wheel cartridge slightly, then re-tighten screws.

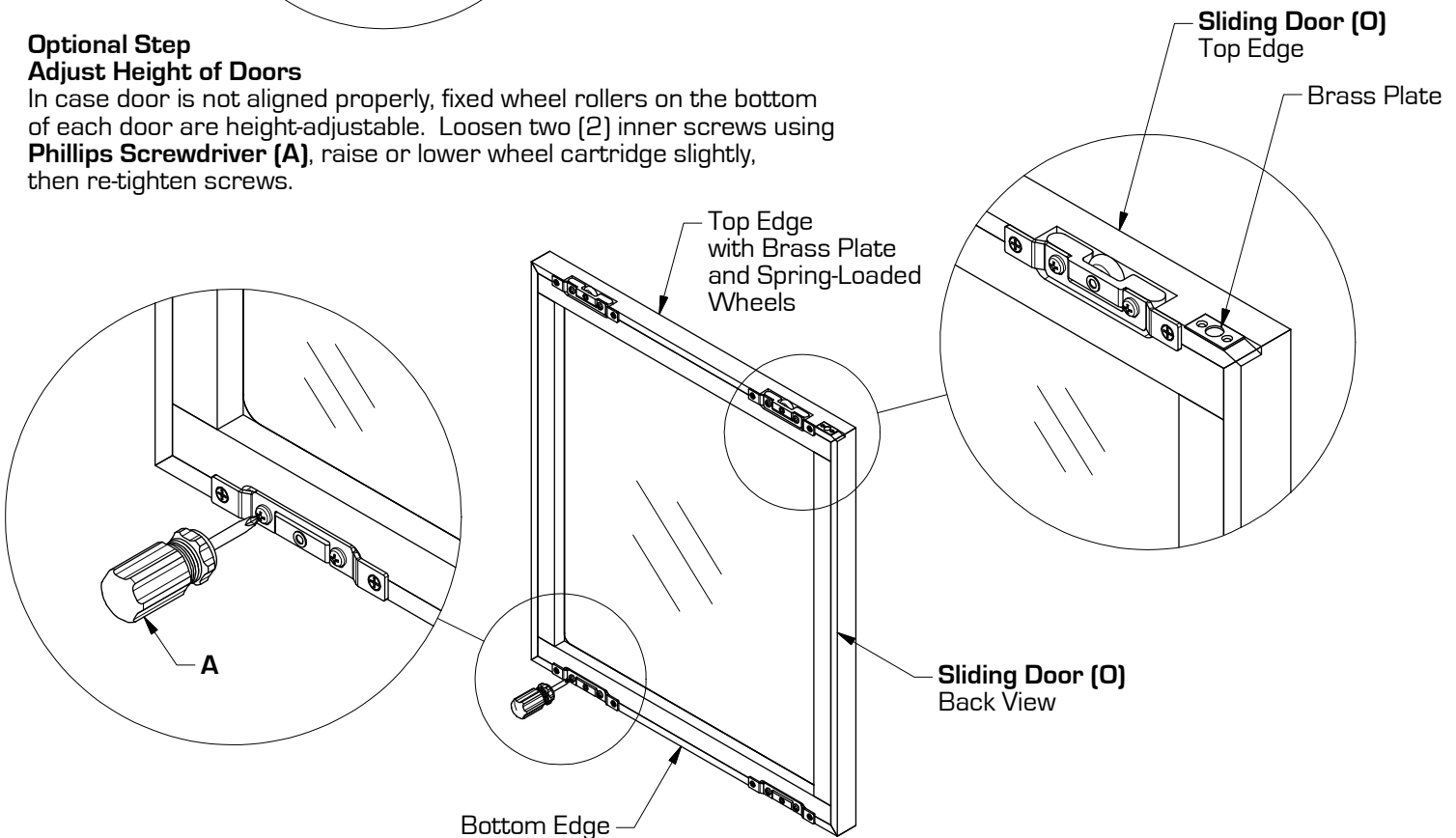

### Step 7

#### Turn Cabinet Over and Install Back Panels

With the help of another person, position the cabinet right side up.

**CAUTION: Do Not Turn Cabinet Over on the Doors.**

Install **Back Panels (P)** to the back side of the cabinet by inserting top edge in upper channel, then tipping bottom edge forward and into lower channel. **NOTE:** Velcro straps are included as wire management for your convenience.

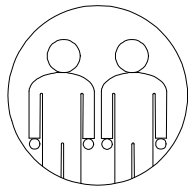

Recommended  
2-person Step

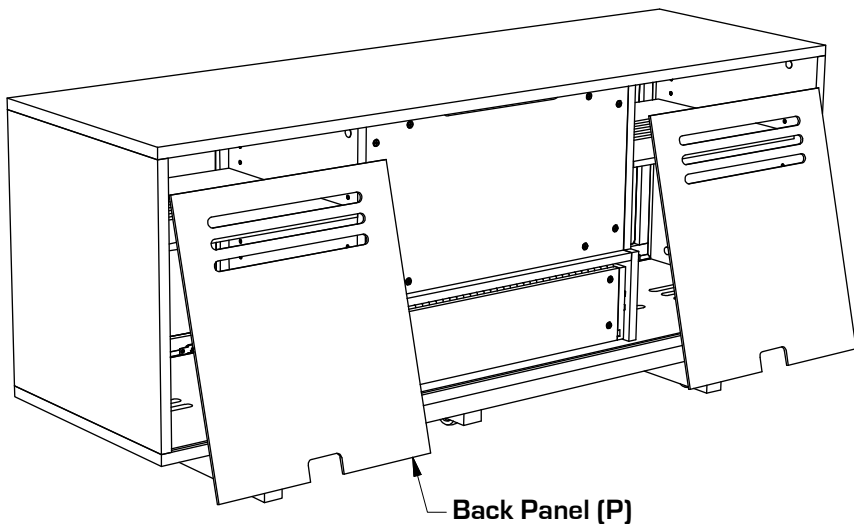

Back Panel (P)

### Step 8

#### Install Adjustable Shelves

Adjustable shelf pins may be repositioned depending on the height of your component, allowing you to raise or lower the Adjustable Shelves (Q) and (R) to the desired level.

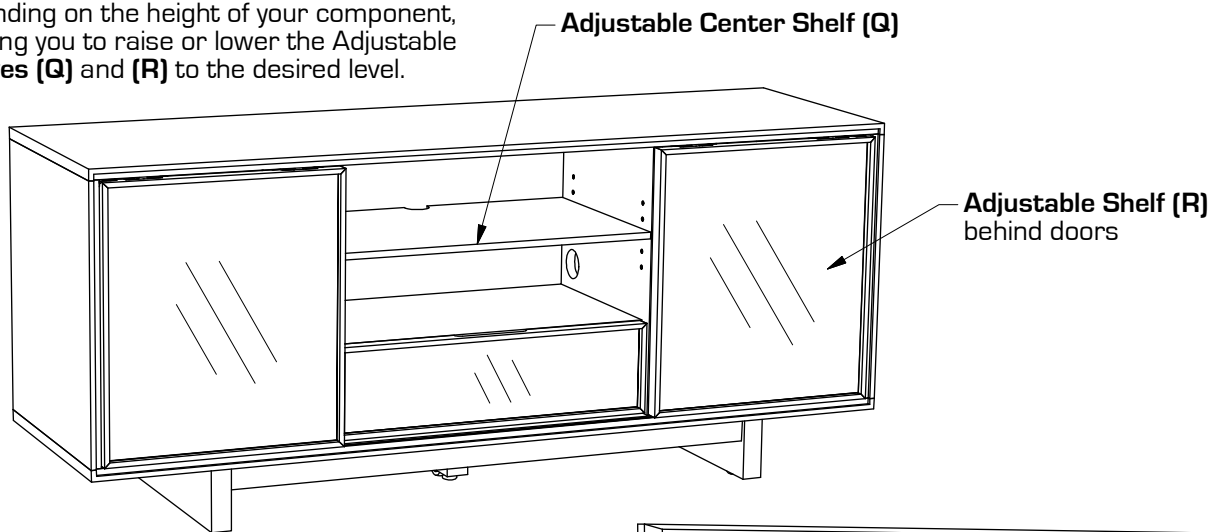

Adjustable Center Shelf (Q)

Adjustable Shelf (R)  
behind doors

#### Optional Flat Panel TV Mount

This BDI cabinet is compatible with **BDI's Flat Panel TV Mount Arena 9972 (sold separately)**, with the following features:

- accommodates most TVs up to 60"
- swivel allows for rotating for optimal viewing
- allows adjustable TV mounting height
- accepts and route cables to and from the TV

For more information, visit [www.bdiusa.com](http://www.bdiusa.com)

